

## Masonry Firebox

### Model MFPST-43

THIS WOOD-BURNING FIREPLACE COMPLIES WITH UL127 STANDARD AS A FACTORY-BUILT APPLIANCE.

**▲WARNING:** THIS FIREPLACE IS APPROVED FOR USE AS A WOOD BURNING FIREPLACE. IT HAS NOT BEEN TESTED OR APPROVED FOR UNVENTED GAS LOGS.

**▲WARNING:** IMPROPER INSTALLATION, ADJUSTMENT, ALTERATION, SERVICE OR MAINTENANCE CAN CAUSE INJURY, PROPERTY DAMAGE OR LOSS OF LIFE. REFER TO THIS MANUAL FOR ASSISTANCE OR ADDITIONAL INFORMATION. CONSULT A QUALIFIED INSTALLER OR LOCAL DISTRIBUTOR.

### SAVE THIS BOOK

This book is valuable. In addition to instructing you on how to install and maintain your appliance, it also contains information that will enable you to obtain replacement parts or accessory items when needed. Keep with your other important papers.

NATIONAL  
FIREPLACE  
INSTITUTE



www.nficertified.org

We recommend that our gas hearth products be installed and serviced by professionals who are certified in the U.S. by the National Fireplace Institute® (NFI) as NFI Gas Specialists.



Report No. 08-154

Do not store gasoline or other flammable vapors and liquids in the vicinity of this or any other appliance.



ICC Evaluation Services  
Report No. 2401

This page has been left intentionally blank.

# CONTENTS

|   |            |
|---|------------|
| Fireplace Parts Diagram for Combustible Floors .....              | Pg. 2      |
| Fireplace Parts Diagram for Non-Combustible Floors .....          | Pg. 3      |
| Fireplace Overall & Framing Dimensions .....                      | Pg. 4      |
| Fireplace Framing Dimensions (Combustible Floor Systems) .....    | Pg. 5      |
| Safety Information .....  | Pg. 6      |
| Product Overview .....  | Pg. 7      |
| Clearance To Combustibles .....                                   | Pg. 8      |
| Mason-Lite Fireplace & Chimney System .....                       | Pg. 8      |
| Supporting Floor Systems .....                                    | Pg. 9, 10  |
| Mason-Lite Weight Determination .....                             | Pg. 10     |
| Mason-Lite™ Component for combustible floors: 8" Metal Base ..... | Pg. 11     |
| Fireplace Assembly Procedures .....                               | Pg.12 ~ 14 |
| Firestop Radiation Shield .....                                   | Pg. 14     |
| Mason-Lite™ Firebrick Liners .....                                | Pg. 15     |
| Fireplace Finishes and Combustible Trim Clearances .....          | Pg. 16     |
| Mantle and Mantle Shelf Clearances .....                          | Pg. 16     |
| Installing Outside Air .....                                      | Pg. 16     |
| Adding a Gas Pipe .....   | Pg. 16     |
| Adding Electrical Connection .....                                | Pg. 16     |
| Mason-Lite Chimney Systems .....                                  | Pg. 17     |
| Installing Damper and Chimney System .....                        | Pg. 17     |
| Fireplace Door Accessory .....                                    | Pg. 17     |
| Mason-Lite Owner's Operation & Precautions .....                  | Pg. 18     |
| Starting A Fire and Basic Operation .....                         | Pg. 18     |
| Annual Fireplace Maintenance .....                                | Pg. 19     |
| Customer Service & Parts Replacement .....                        | Pg. 19     |
| Appendix I .....  | Pg. 20     |
| Appendix II .....   | Pg. 21     |

Below is a sample picture of the rating plate that is located inside the lower dome side of your fireplace. Serial number and date code should be stamped on the plate where required.



315 WEST 3RD ST.  
SANTA ANA, CA 92701

**DO NOT REMOVE THIS LABEL**

See MFI's installation and operating instructions for this model. Contact local building officials about restrictions and installation specifications in your area.

Report No.  
08-154



ICC Evaluation  
Services Report  
No. 2401



MODEL No.: **MFPST43**

|   |   |  |   |                              |                              |                             |                             |  |                       |   |             |                           |              |                           |              |                                    |              |                                    |              |                              |            |
|---|---|--|---|------------------------------|------------------------------|-----------------------------|-----------------------------|--|-----------------------|---|-------------|---------------------------|--------------|---------------------------|--------------|------------------------------------|--------------|------------------------------------|--------------|------------------------------|------------|
| <p><b>⚠ WARNING:</b><br/>THIS FIREPLACE HAS BEEN TESTED FOR USE ONLY WITH APPROVED GLASS DOORS. TO REDUCE THE RISK OF FIRE OR INJURY, CONSULT OWNER'S MANUAL.</p> | <p><b>⚠ THIS FIREPLACE IS DESIGNED FOR USE ONLY WITH SOLID WOOD LOGS, PLUMBED LPG OR NG LOG LIGHTERS OR PLUMBED ANSI Z21.60 DECORATIVE GAS LOGS.</b><br/>Consult instructions included with this firebox for further information.</p> | <p><b>⚠ WARNING:</b><br/>Use only approved, listed UL103-16" I.D. Class A Chimney System. Please refer to pipe mfg. installation instructions.</p> <p><b>Chimney Height:</b><br/>Max.: 40 ft.<br/>Min.: 14 ft.<br/>(17 ft. with 1 or 2 offset sections maximum)</p>  | <p><b>FIREPLACE CLEARANCES TO COMBUSTIBLES:</b></p> <table border="0"> <tr><td>UNIT FRONT, SIDES, REAR.....</td><td>2" (50 mm)</td></tr> <tr><td>COMBUSTIBLE FLOOR.....</td><td>8" (200 mm)</td></tr> <tr><td>COMBUSTIBLE SHEATHING ABOVE OPENING TOP.....</td><td>8" (200 mm)</td></tr> <tr><td>SHEATHING OR TRIM TO OPENING SIDES.....</td><td>8" (200 mm)</td></tr> <tr><td>MANTLE ABOVE OPENING.....</td><td>12" (300 mm)</td></tr> <tr><td>OPENING TO SIDE WALL.....</td><td>24" (600 mm)</td></tr> <tr><td>HEARTH EXTENSION BEYOND FRONT.....</td><td>20" (500 mm)</td></tr> <tr><td>HEARTH EXTENSION BEYOND SIDES.....</td><td>12" (300 mm)</td></tr> <tr><td>INSULATION FROM FIREBOX.....</td><td>2" (50 mm)</td></tr> </table> | UNIT FRONT, SIDES, REAR..... | 2" (50 mm)                   | COMBUSTIBLE FLOOR.....      | 8" (200 mm)                 | COMBUSTIBLE SHEATHING ABOVE OPENING TOP..... | 8" (200 mm)           | SHEATHING OR TRIM TO OPENING SIDES..... | 8" (200 mm) | MANTLE ABOVE OPENING..... | 12" (300 mm) | OPENING TO SIDE WALL..... | 24" (600 mm) | HEARTH EXTENSION BEYOND FRONT..... | 20" (500 mm) | HEARTH EXTENSION BEYOND SIDES..... | 12" (300 mm) | INSULATION FROM FIREBOX..... | 2" (50 mm) |
| UNIT FRONT, SIDES, REAR.....  | 2" (50 mm)  |  |   |                              |                              |                             |                             |  |                       |   |             |                           |              |                           |              |                                    |              |                                    |              |                              |            |
| COMBUSTIBLE FLOOR.....  | 8" (200 mm)   |  |   |                              |                              |                             |                             |  |                       |   |             |                           |              |                           |              |                                    |              |                                    |              |                              |            |
| COMBUSTIBLE SHEATHING ABOVE OPENING TOP.....  | 8" (200 mm)   |  |   |                              |                              |                             |                             |  |                       |   |             |                           |              |                           |              |                                    |              |                                    |              |                              |            |
| SHEATHING OR TRIM TO OPENING SIDES.....   | 8" (200 mm)   |  |   |                              |                              |                             |                             |  |                       |   |             |                           |              |                           |              |                                    |              |                                    |              |                              |            |
| MANTLE ABOVE OPENING.....   | 12" (300 mm)  |  |   |                              |                              |                             |                             |  |                       |   |             |                           |              |                           |              |                                    |              |                                    |              |                              |            |
| OPENING TO SIDE WALL.....   | 24" (600 mm)  |  |   |                              |                              |                             |                             |  |                       |   |             |                           |              |                           |              |                                    |              |                                    |              |                              |            |
| HEARTH EXTENSION BEYOND FRONT.....  | 20" (500 mm)  |  |   |                              |                              |                             |                             |  |                       |   |             |                           |              |                           |              |                                    |              |                                    |              |                              |            |
| HEARTH EXTENSION BEYOND SIDES.....  | 12" (300 mm)  |  |   |                              |                              |                             |                             |  |                       |   |             |                           |              |                           |              |                                    |              |                                    |              |                              |            |
| INSULATION FROM FIREBOX.....  | 2" (50 mm)  |  |   |                              |                              |                             |                             |  |                       |   |             |                           |              |                           |              |                                    |              |                                    |              |                              |            |
| <p>THIS APPLIANCE NEEDS FRESH AIR FOR SAFE OPERATION AND MUST BE INSTALLED SO THERE ARE PROVISIONS FOR ADEQUATE COMBUSTION AND VENTILATION AIR.</p>               |   | <table border="0"> <tr> <td style="width: 50%;"><b>MANTEL CLEARANCES</b></td> <td style="width: 50%;"><b>MANTEL ABOVE OPENING:</b></td> </tr> <tr> <td>0" - 3" : 1-1/2" MAX. PROJ.</td> <td>MIN. - 3" SHEATHING OR TRIM</td> </tr> <tr> <td>3' - 12" : 1-1/2" - 8" MAX. PROJ.</td> <td>TO OPENING SIDES - 8"</td> </tr> </table> |   | <b>MANTEL CLEARANCES</b>     | <b>MANTEL ABOVE OPENING:</b> | 0" - 3" : 1-1/2" MAX. PROJ. | MIN. - 3" SHEATHING OR TRIM | 3' - 12" : 1-1/2" - 8" MAX. PROJ.            | TO OPENING SIDES - 8" |   |             |                           |              |                           |              |                                    |              |                                    |              |                              |            |
| <b>MANTEL CLEARANCES</b>  | <b>MANTEL ABOVE OPENING:</b>  |  |   |                              |                              |                             |                             |  |                       |   |             |                           |              |                           |              |                                    |              |                                    |              |                              |            |
| 0" - 3" : 1-1/2" MAX. PROJ.   | MIN. - 3" SHEATHING OR TRIM   |  |   |                              |                              |                             |                             |  |                       |   |             |                           |              |                           |              |                                    |              |                                    |              |                              |            |
| 3' - 12" : 1-1/2" - 8" MAX. PROJ.   | TO OPENING SIDES - 8"   |  |   |                              |                              |                             |                             |  |                       |   |             |                           |              |                           |              |                                    |              |                                    |              |                              |            |

**LISTED MASONRY FIREPLACE SYSTEM COMPLIES WITH APPLICABLE REQUIREMENTS OF UL127**

Fireplace is designed for installation per the National Fire Protection Association Standard for Chimneys, Fireplaces, Vents and Solid Fuel-Burning Appliances (NFPA 211).

**⚠ WARNING:** THIS FIREPLACE HAS NOT BEEN TESTED WITH AN UNVENTED GAS LOG SET. TO REDUCE THE RISK OF FIRE OR INJURY, DO NOT INSTALL AN UNVENTED GAS LOG SET INTO FIREPLACE.

rev.09\_18 NOV 2009

# MFPST-43 Fireplace Parts Diagrams

## Combustible Floor Systems

## Non-Combustible Floor Systems

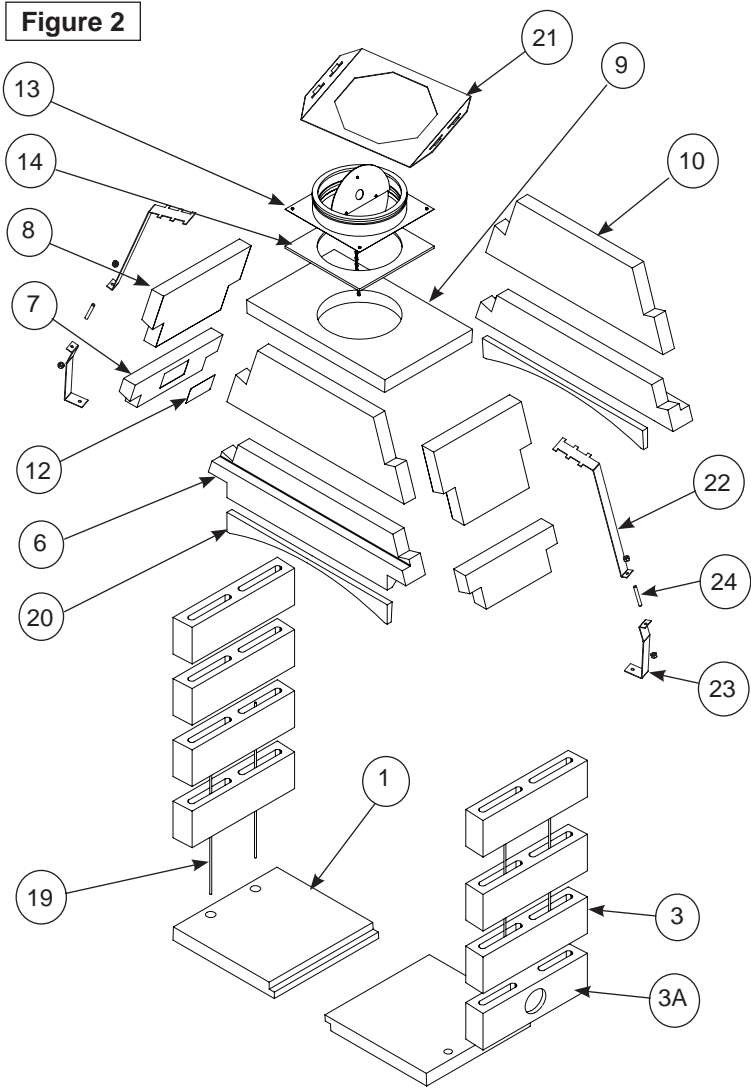
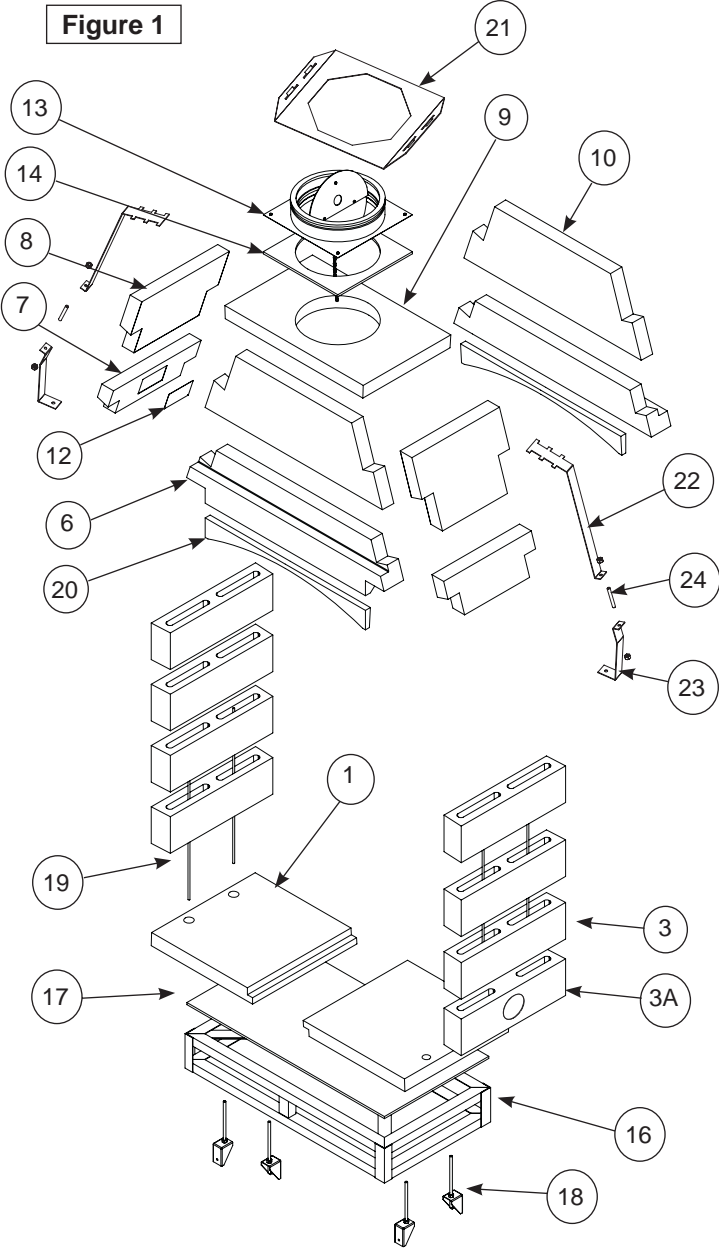

# MFPST-43 Fireplace Parts List

**Optional Outside Ø4”  
Combustion Air Kit  
Model No.: MFP4-AK**

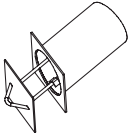

**(Ø4” Ducting not included)**

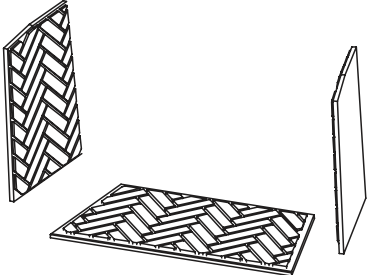

**MFP43SHBL- Herringbone  
MFP43FRBL- Running Bond**

**Refractory Firebrick Liners**  
(Herringbone Pattern shown, also available  
in Running Bond - see Pg.27)

| ITEM | P/N          | DESCRIPTION                        | QTY |
|------|--------------|------------------------------------|-----|
| 1    | MFPST-43-1   | HEARTH (Left or Right)             | 2   |
| 3    | MFPST-43-3   | SIDE WALL                          | 5   |
| 3A   | MFPST-43-3A  | SIDE WALL W/4” KNOCKOUT            | 1   |
| 6    | MFPST-43-6   | LINTEL                             | 1   |
| 7    | MFPST-43-7   | DOME SIDE - LOWER                  | 2   |
| 8    | MFPST-43-8   | DOME SIDE - UPPER                  | 2   |
| 9    | MFPST-43-9   | DOME TOP FOR 16” CLASS A CHIMNEY   | 1   |
| 10   | MFPST-43-10  | DOME FRONT/REAR - UPPER            | 2   |
| 12   | MFP521       | RATING PLATE, MFP33                | 1   |
| 13   | NOT SUPPLIED | Ø16” DAMPER / ANCHOR PLATE         | --- |
| 14   | NOT SUPPLIED | INSULATION BLANKET                 | --- |
| 16   | MFPBST43 *   | STEEL SUPPORT PLATFORM 8 INCH HIGH | 1   |
| 17   | NOT SUPPLIED | CEMENT BOARD, MFPST43              | --- |
| 18   | MFP5B *      | ASSY, FLOOR JOIST BRACE            | 4   |
| 19   | MF49-11      | #3 REBAR (Ø3/8”) x 36”             | 8   |
| 20   | MFP-ARC      | LINTEL TRIM (OPTIONAL)             | 2   |
| 21   | MFP116-16 *  | COLLAR, TENSION STRAP 16”          | 1   |
| 22   | MFP117 *     | TENSION STRAP, UPPER               | 2   |
| 23   | MFP118 *     | TENSION STRAP, LOWER               | 2   |
| 24   | MFP119 *     | TENSION STRAP HARDWARE PACK        | 1   |

\* ITEMS NOTED ARE SOLD SEPARATELY

ITEMS INDICATED AS “NOT SUPPLIED” CAN BE OBTAINED FROM YOUR LOCAL HARDWARE STORE.

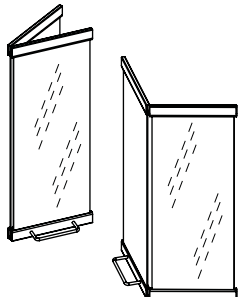

**Only the following  
doors have been tested  
and approved for use  
with this fireplace:**  
Crown-Breckinridge  
or  
McKenzie-Pendelton

# MFPST-43 Fireplace Overall Dimensions

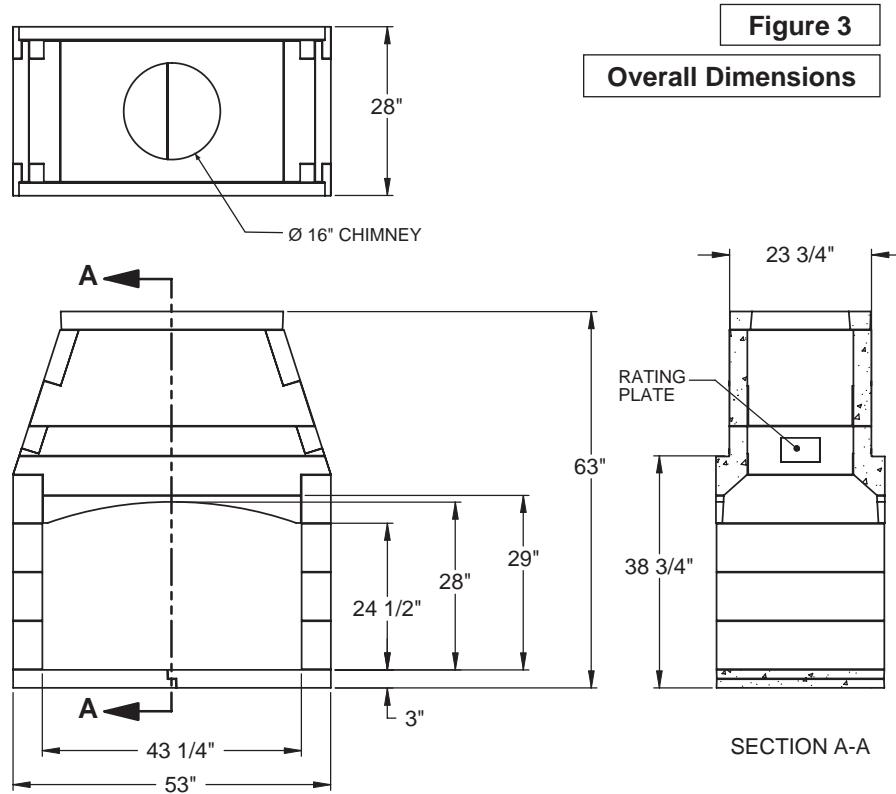

# Fireplace Framing Dimensions

**Figure 4**

## Non-Combustible Floor Systems

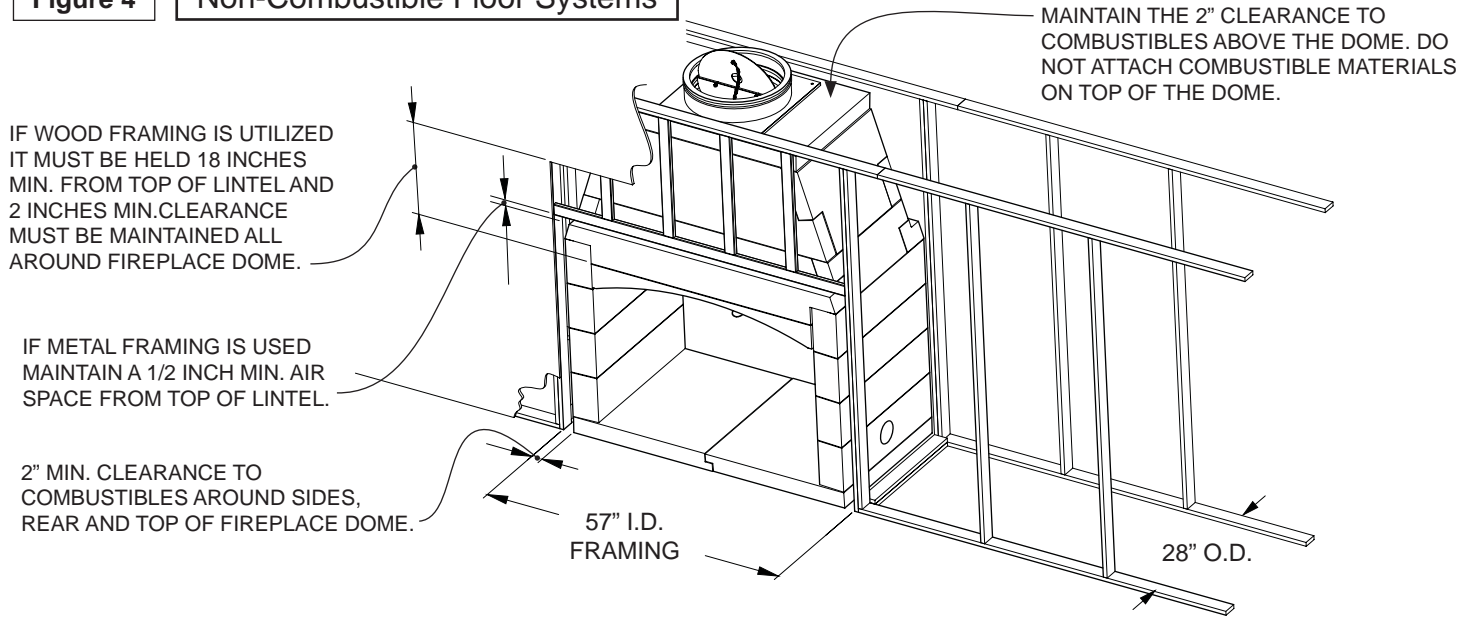

### ⚠ WARNING

Failure to position the parts in accordance with these diagrams or failure to use only parts specifically approved with this appliance may result in property damage or personal injury.

# Fireplace Framing Dimensions (Combustible Floor Systems)

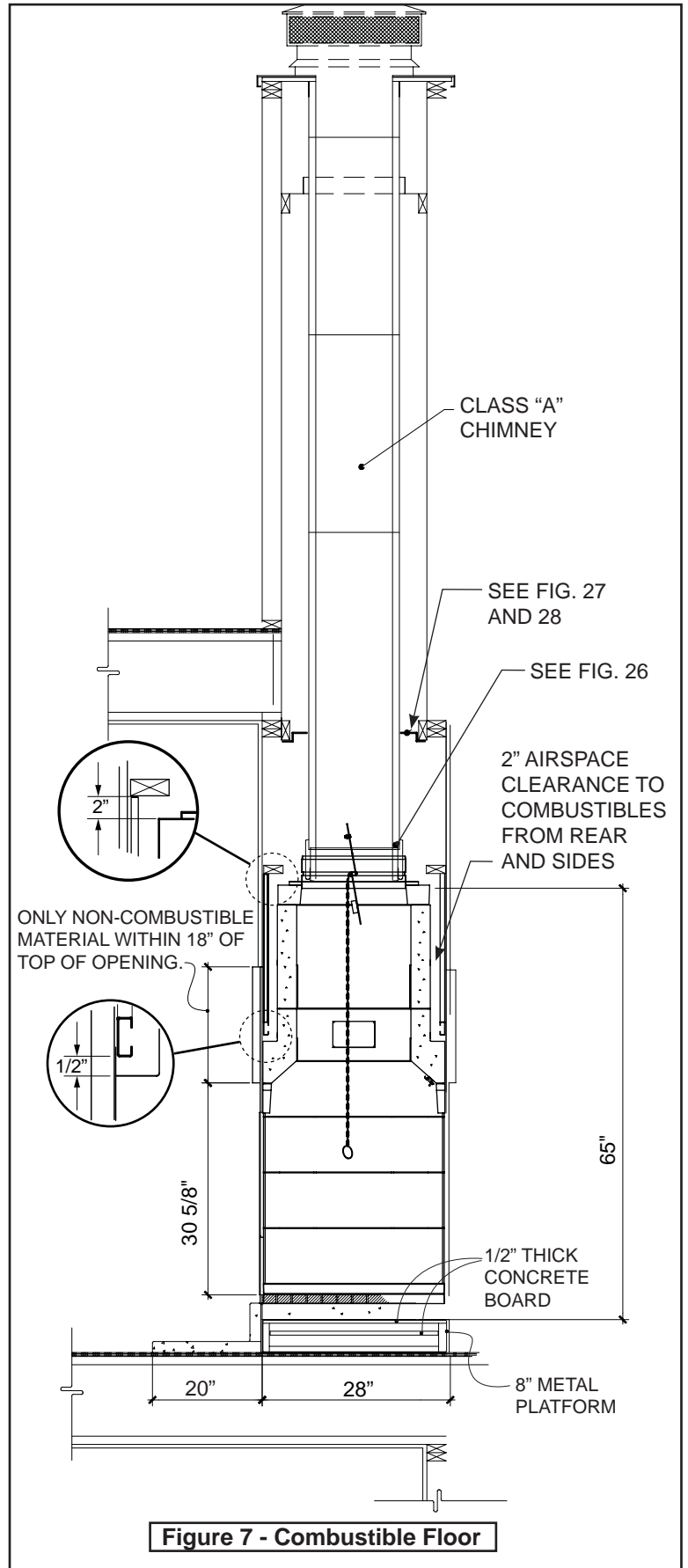
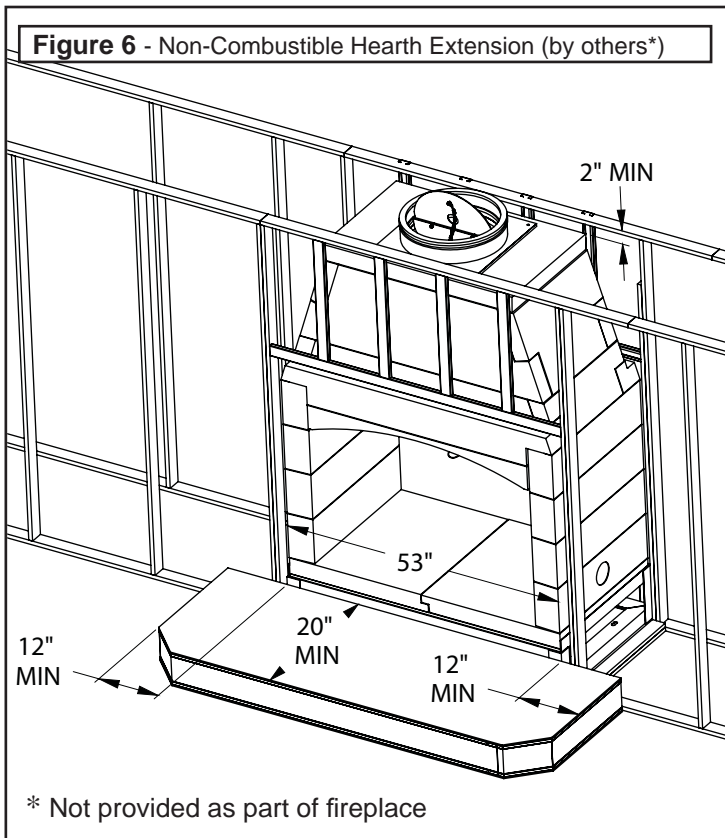
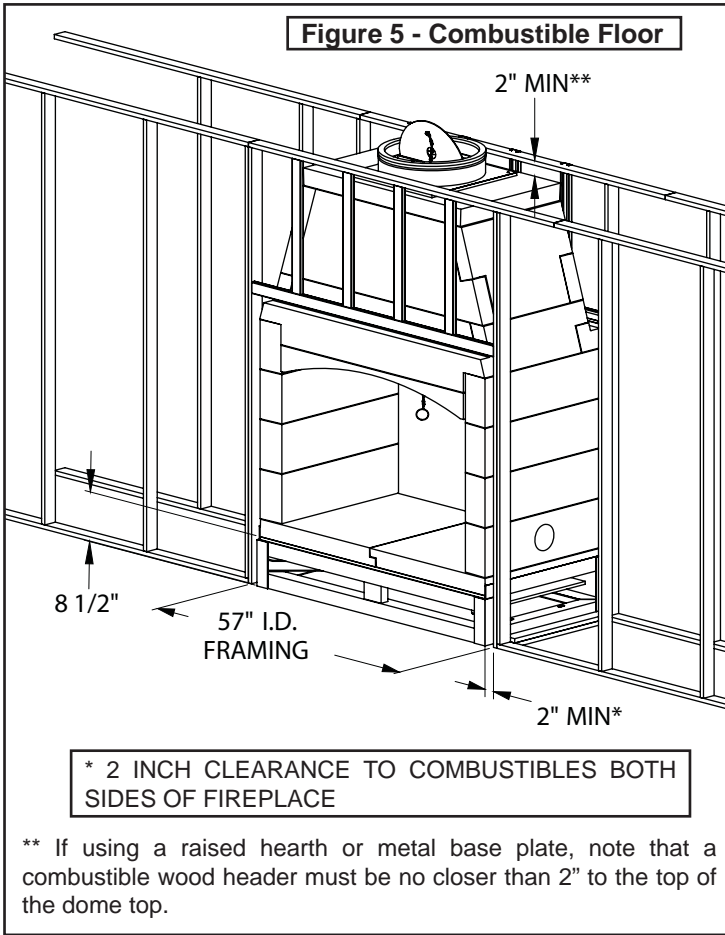

## Safety Information

**WARNING:** THIS FIREPLACE HAS NOT BEEN TESTED FOR USE WITH AN UNVENTED GAS LOG SET. TO REDUCE THE RISK OF FIRE OR INJURY, DO NOT INSTALL AN UNVENTED GAS LOG SET INTO FIREPLACE.

**WARNING:** THIS FIREPLACE HAS BEEN TESTED FOR USE WITH OPTIONAL GLASS DOORS: CROWN-BRECKINRIDGE OR MCKENZIE-PENDELTON ONLY.

**WARNING:**  
Install only approved, listed UL 103-16" I.D. Class A Chimney System.

Chimney maximum height: 40 feet

Chimney minimum height: 14 feet (with offset = 17 feet)  
2 offsets maximum.

**Important:** Follow the chimney pipe manufacturer's instructions on the installation of their specific flue system.

### GUIDELINES FOR USE:

All current and future users of Mason-Lite Fireplaces are charged with the responsibility for full knowledge of the information contained within this manual which includes:

Strict requirements for assembly.

Detailed instructions for installation.

Cautionary guidelines for use.

On-going maintenance instructions.

It is the responsibility of the distributor, subcontractor and/or the general contractor – whoever shoulders the liability for installation of this product – to see to it that the work is in complete compliance with the guidelines and instructions in this manual. Note that the general contractor is the party accountable for seeing that adequate clearances are provided from all firebox surfaces per specifications in this manual.

---

**DO NOT USE A FIREPLACE INSERT OR OTHER PRODUCTS NOT SPECIFIED FOR USE WITH THIS FIREPLACE.**

---

### **The Mason-Lite is Designed for Use Only with:**

- Solid Wood Logs
- Plumbed LPG or Natural Gas Log Lighter.
- Plumbed ANSI Z21.60 Decorative Gas Log.

**DO NOT USE OR STORE GASOLINE OR OTHER FLAMMABLE LIQUIDS OR GASES IN OR NEAR THE FIREPLACE!**

**ATTENTION:** A fire or an explosion could occur causing property damage, injury or loss of life if you do not follow the information in this manual!

**NOTE:** THIS MANUAL MUST BE REPRODUCED ONLY IN ITS ENTIRETY.

### **Before Beginning the Installation**

Read these instructions carefully before beginning the installation of this fireplace. Also, if installing an ANSI Z21.60 Decorative Gas Log, read the gas log appliance manufacturer's literature regarding sizing and suitability for the installation into this Enclosure prior to installation.

### **Statement of Intended Use:**

The Mason-Lite Masonry Fireplace is a modular refractory masonry unit designed for field assembly. The firebox is constructed using pre-cast, interlocking refractory blocks. The blocks are then secured to each other using Mortar. The system includes all parts necessary for the assembly of a complete masonry fireplace. In addition to the basic enclosure, a standard 1-1/8" thick, high temperature refractory brick is required to line the interior of the firebox.

These fireplaces are not intended to serve as a primary heat source, rather, the fireplace was expressly created as a supplemental source of heat. The unit is designed for use with solid fuels such as cord wood.

### **WARNING:**

Any application other than the "Intended Use" as stated above is in violation of the manufacturer's instructions and is hereby prohibited. Such violation may cause immediate hazard, property damage or loss of life and will void all liabilities to the manufacturer and will void all warranties explicit or implied.

# Product Overview

## Introduction

We extend a warm welcome from all of us at Masonry Fireplace Industries, LLC. (MFI), proud manufacturers of Mason-Lite Fireplaces. Thank you for choosing MFI.

You may have thought long and hard before you chose the fireplace which would grace your home. Rest assured that every component of the Fireplace has been tested to ensure long-term durability.

## Product Overview

Mason-Lite Fireplaces are designed as factory-built blocks to be assembled on-site. These fireplaces may be installed on either combustible or non-combustible floors. In order for the fireplace to be installed on a combustible floor though, it is necessary that the fireplace be supported on a platform or sub-floor that is non-combustible.

### The Four Components of the Mason-Lite Fireplace:

- Combustible or Non-Combustible Floor
- Non-Combustible Raised Platform
- MASON-LITE Firebox and Smoke Dome
- UL103-16" class A listed chimney system required.  
**Important:** Follow the chimney pipe manufacturer's instructions on the installation of their specific flue system.

Careful step-by-step instructions for each phase of the installation procedure will be given for the Mason-Lite conventional radiant heat fireplaces. Those instructions generally fall into the following categories:

- Spacing and clearance as it relates to combustible materials.
- Familiarity of installation for all components.
- The strength of the floor on which it rests.
- Chimney system measurements.
- Choice of materials and craftsmanship in fireplace and hearth finishing.
- 

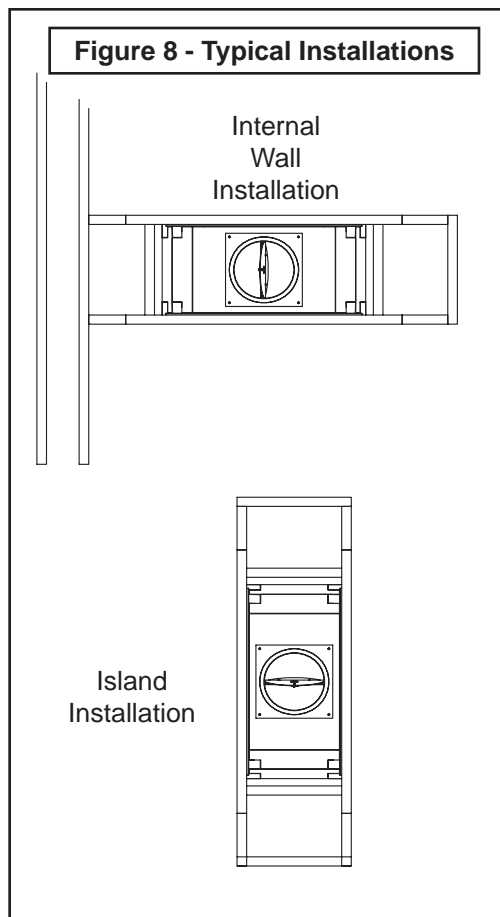

Note that each of these topics will be covered in detail and that the installer is expected to understand each phase completely before going on to subsequent instructions.

**Attention:** Be advised that all the illustrations in this manual are for general reference only. Do not scale drawings. Actual design elements will vary from case to case. Pay attention to specified minimum clearances to combustibles.

Testing and listing for the Mason-Lite Fireplace has been undertaken by PFS Inc. (Report No. 08-154) to UL 127.

**Attention:** You may need a residential building permit to install a Mason-Lite Fireplace. Consult local jurisdictions before you get started!

If asked, advise the local authorities that the Mason-Lite Fireplace is designed for installation per the National Fire Protection Association Standard for Chimneys, Fireplaces, Vents and Solid Fuel-Burning Appliances (NFPA211).

When choosing the location of your Mason-Lite Fireplace, keep in mind you must maintain 2" (two inches) minimum clearance from left, right and rear of Fireplace to surrounding structure. Also, when choosing a location, consider outside air requirements to determine if it will be on the left or right side of the Fireplace. In the case of an island installation, outside air accessibility may be obtained through sub-flooring. See section on Installing Outside Air on page 17.

## Clearances to Combustibles

The distance to be maintained from the surfaces of the fireplace to combustibles must be observed. Below is a list of the most common combustible materials to name a few:

|              |                  |                |
|--------------|------------------|----------------|
| Drywall      | Wood flooring    | Plywood        |
| Sub-flooring | Wood Framing     | Particle board |
| Mill board   | Plywood paneling |                |

### Maintain the following clearances:

- Unit front, sides, rear: 2" (50 mm)
- Combustible Floor: 8" (150 mm)
- Combustible Sheathing above opening top: 8" (200 mm)
- Sheathing or trim to opening sides: 8" (200 mm)
- Mantel above opening: (refer to **Fig.9**)
- Opening to sidewall: 24" (500 mm)
- Hearth extension beyond front: 20" (500 mm)
- Hearth extension beyond sides: 12" (300 mm)
- Insulation from firebox: 2" (50 mm)

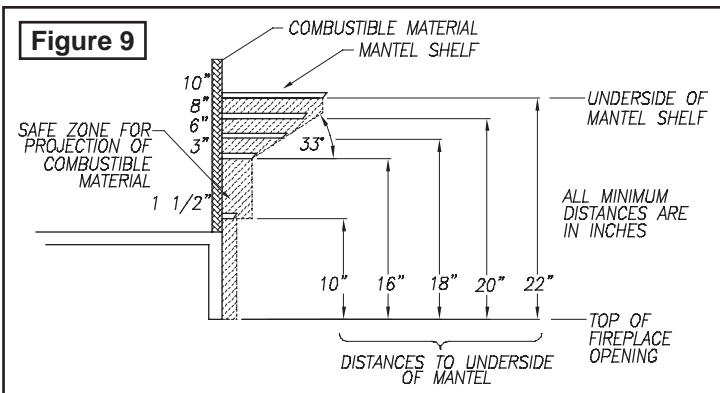

### Understanding Clearance to Combustibles

There is a build-up of considerable amount of radiant heat on the outer surfaces of the Mason-Lite™ Fireplace. It's critical that proper clearances to combustibles be maintained so that this radiant heat is maintained to safe limits.

## Combustible Floor Clearances

MFPST-43 Mason-Lite Fireplaces have been designed with clearance to combustible floors at a minimum of 8-1/2" (eight and one half inches) as provided by the 8" metal base and 1/2" concrete board. Cover any part of the combustible floor system left exposed with 1" (one inch) thick ceramic fiber insulation rated up to 2,100°F.

The Mason-Lite Steel Platform, the 1/2" concrete board above, the 1" ceramic fiber blanket or board within the platform (**Fig.15**) and the 2" clearance for dome front, and unit sides provide the temperature safety margin to combustible materials.

## Mason-Lite Fireplace & Chimney System

Prior to starting the installation, check with local, regional or state codes for any restrictions or required permits regarding your fireplace installation.

- 1) The Mason-Lite is designed to be installed with a listed UL-103-16" I.D. Class A, Metal Chimney System.
- 2) This Mason-Lite fireplace is intended as a supplemental heat source only. It is not intended as a primary heat source.
- 3) It is the responsibility of the contractor installer (not the manufacturer) to ensure that adequate combustion air is provided for proper function of this fireplace. Fireplaces take up a large volume of replacement air from outside the house and if the house is of airtight construction, smoke spillage may occur if proper draft is not achieved.
- 4) There are many conditions beyond a manufacturer's control regarding improper fireplace operation. The manufacturer cannot ensure "smoke free" operation, nor can the manufacturer take on the responsibility for problems with surrounding construction; chimneys that have not been built at the right heights; system drafts caused by faulty mechanical systems; adverse weather conditions or any other inclement environmental situations over which the manufacturer has no control.
- 5) Inspect all fireplace & chimney components for evidence of damage prior to starting installation. Consult your local distributor for replacement parts if necessary.
- 6) Under no circumstances should you make any adjustments or modifications to the chimney system during the installation procedure. If you do, you are not only liable for negating the warranty, but you could very well cause a serious malfunction of the fireplace. You must follow your chimney manufacturer's instructions.
- 7) Caution is urged if it is decided to add insulation material to any part of the Mason-Lite Fireplace or Chimney system, be certain that the insulation material is kept at least 2" (two inches) away from any part of the system. When using insulation or vapor barrier materials, cover with a layer of plywood, particle board or gypsum board to maintain the specified 2" (two inch) clearance.
- 8) Air spaces around firebox must remain open. DO NOT fill these open spaces with insulation or packing material of any kind.

## Chimney System Heights

When installed, the **maximum** overall height of the chimney system from bottom of fireplace to the top/termination chimney is 40 feet. The **minimum** installed height of the completed Chimney System is 14 feet with a straight flue stack, 17 feet if the chimney includes one or two offset sections.

## Supporting Floor Systems

It is the ultimate responsibility of the installer to ensure that proper concrete slab supports are used.

**WARNING** to the licensed design professional and/or building contractor: It is your responsibility to be certain that the Mason-Lite can be properly supported by the combustible floor system on which the fireplace will rest.

For fireplace support foundations installed on concrete refer to Appendix I and II (pages 20 & 21 ) for specific instructions.

### Rebar locations

Lay-out the position of the fireplace and drill holes where the rebar will be located. Secure eight #3 rebar 4 inches into concrete foundation with ITW Epoxy or Simpson Epoxy. Follow manufacturer's instructions for installation of rebar into slab.

### Wood Floor

Anchorage of fireplace to wood floor construction is required. Refer to **Figure 10** for anchorage locations. Four anchors are required to attach to the sub-flooring framing.

### Crawl Space or Upper Floor:

For installation of firebox over combustible crawl spaces or upper floors, anchorage of the firebox is required. Illustrations of examples of possible anchorage methods are shown in Figures 10 thru 13 depending upon the type of floor framing. Final method of anchorage to be determined by licensed design professional.

For conventional framing where the floor joists are parallel with the sides of the firebox, the addition of floor joists to align with the anchor brackets allows the brackets to be directly connected to the floor joists.

Note that additional floor joists may be required to support the weight of the firebox and chimney. Where the floor joists run parallel to the front of the firebox, anchorage can be accomplished in like manner as shown in Figure 12 using blocking between the floor joist.

For floors supported by I-Joists, the method of anchorage is illustrated in Figures 10 and 11. Figure 12 illustrates the general arrangement of anchorage to floor framing.

It is important to take into consideration that the load for the Mason-Lite Fireplace must be considered as additional dead load that will have to be supported by the floor framing. Additional floor joists or I-joists may be required as determined by the licensed design professional.

The weights to be considered are noted in **Table I**. It is the task and responsibility of the general contractor/installer to see that the proper reinforcement for weight loads are made by a licensed design professional prior to the fireplace installation.

As stated above, it is desirable to place additional framing for alignment of anchor rods. Refer to **Figure 14** for anchor rod locations.

Attach the firebox side wall anchors to steel support frame by inserting all-thread side rods through holes on the bottom flange on the steel support frame as shown in **Figure 14**. Secure with two  $\varnothing 2"$  o.d. x  $\varnothing 9/16"$  i.d. x 0.10" Washers and two 1/2-13 UNC Nuts.

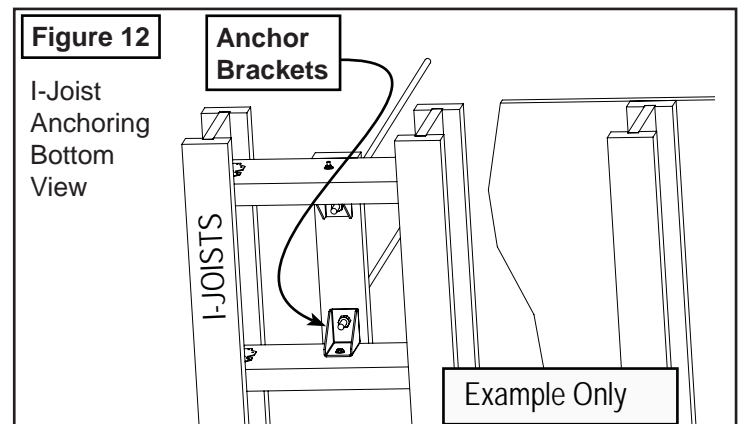
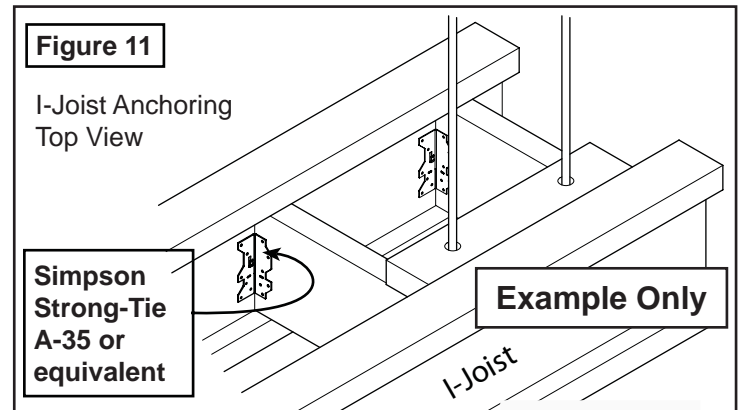
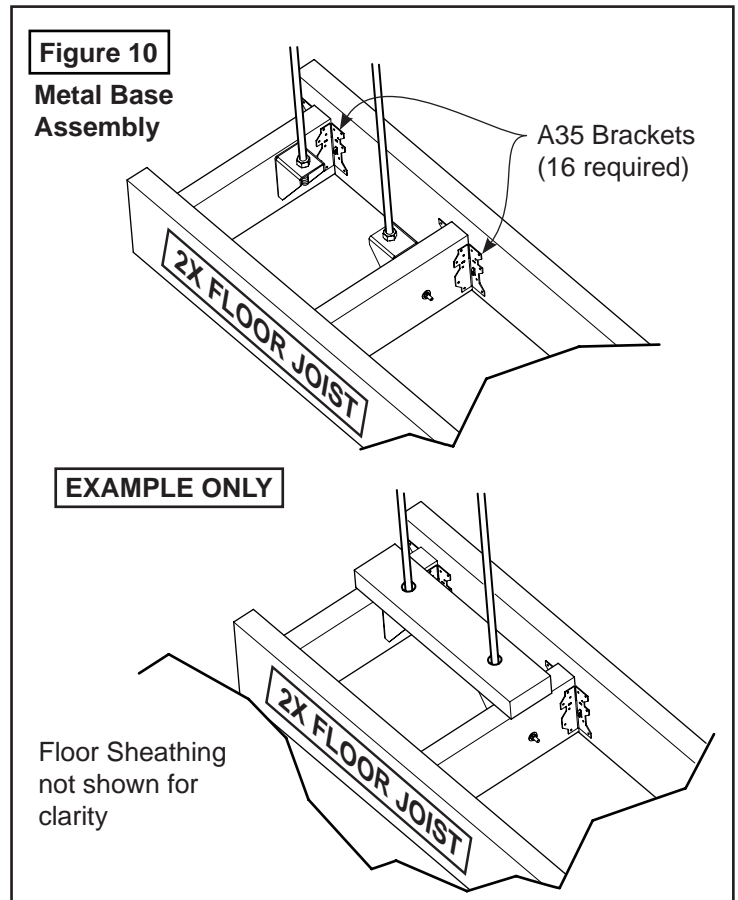

## MASON-LITE Weight Determination

The following are dead load weight estimates for the Mason-Lite Fireplace.

| Table I                                 |                                 |
|---|---------------------------------|
| Model:                                  | MFPST-43                        |
| Fireplace                               | 835 lb..                        |
| Damper/Anchor Plate, Firebrick & Mortar | 350 lb..                        |
| Steel Platform                          | 70 lb..                         |
| Floor Area                              | 53" x 28"<br>(10.3 square feet) |

### Other Weight Considerations:

- 1) Fireplace finished facing (surround): This information needs to be obtained from the contractor.
- 2) Weight of metal flue: See chimney manufacturer's weight specifications. Some chimney systems can weigh up to 50 lb. per linear foot.

| Table II - Deflection Limits |       |        |                    |
|------------------------------|-------|--------|--------------------|
| Construction                 | L     | S or W | D + L <sub>1</sub> |
| Floor Members                | 1/360 | ---    | 1/240              |

<sup>1</sup> For wood structural members having a moisture content of less than 16 per cent at time of installation and used under dry conditions, the deflection resulting from L + 0.5D is permitted to be substituted for the deflection resulting from L + D.

Note that MASON-LITE cannot accept responsibility for structural floor support details. All drawings are presented as mere illustrations to indicate the presence of the underlying floor system. It is the responsibility of the general contractor/installer to consult with a local licensed design professional for guidance in building a proper floor support system.

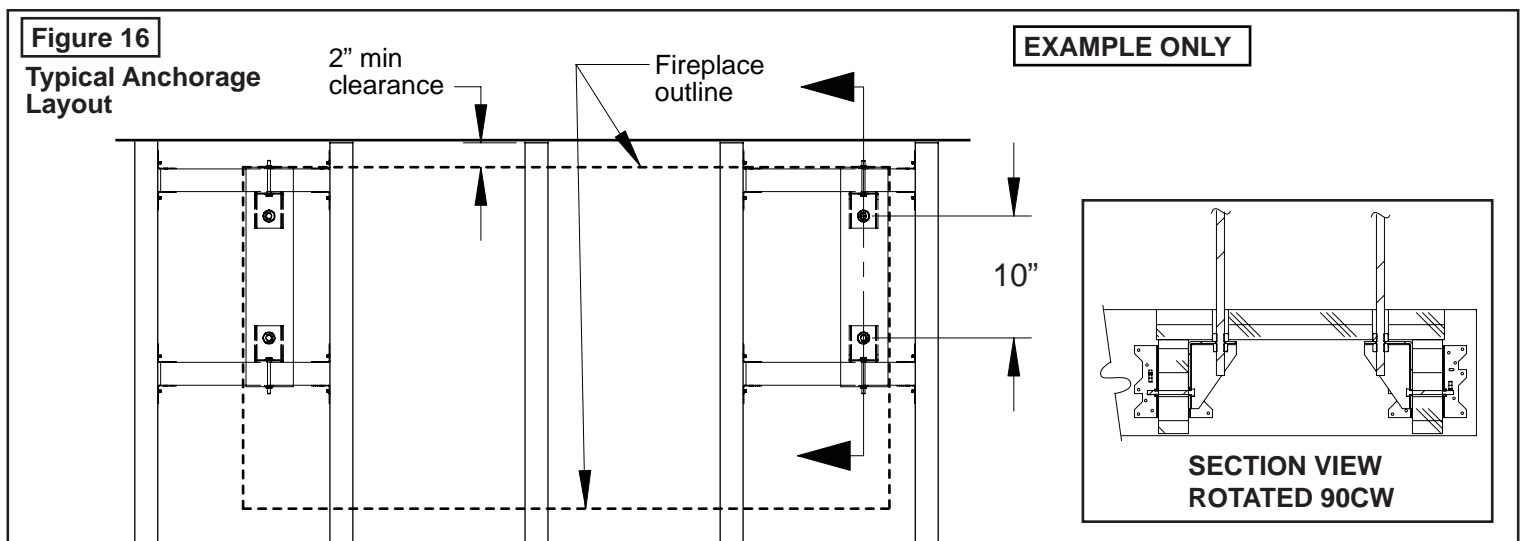
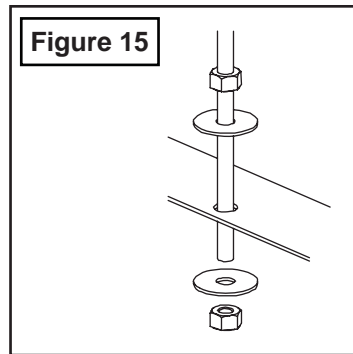
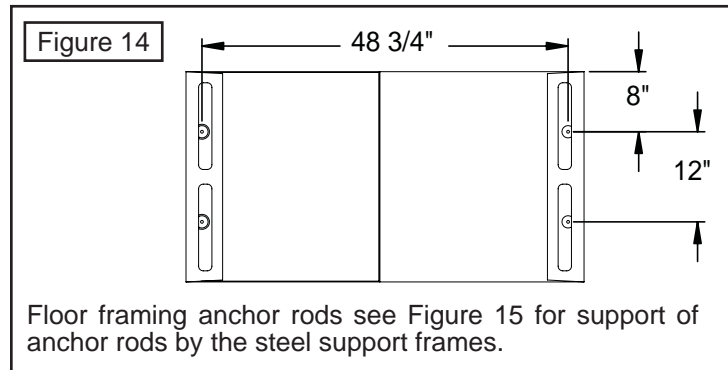

## Combustible Floor Installations

### 8" Metal Base

The Mason-Lite Metal Base ensures the minimum 8" (eight inch) clearance above combustible flooring is maintained.

A layer of 1/2" minimum Concrete Board is required on the top and mid section below as shown in **Figure 17**. The required sizes are shown in the table below.

| 1/2" Thick Cement Board Dimensions |     |     |     |     |
|------------------------------------|-----|-----|-----|-----|
| Model                              | A1  | A2  | B1  | B2  |
| MFPST-43                           | 53" | 28" | 48" | 23" |

**Figure 17** MFP-33/39/44/49: 6" Metal Base Assembly

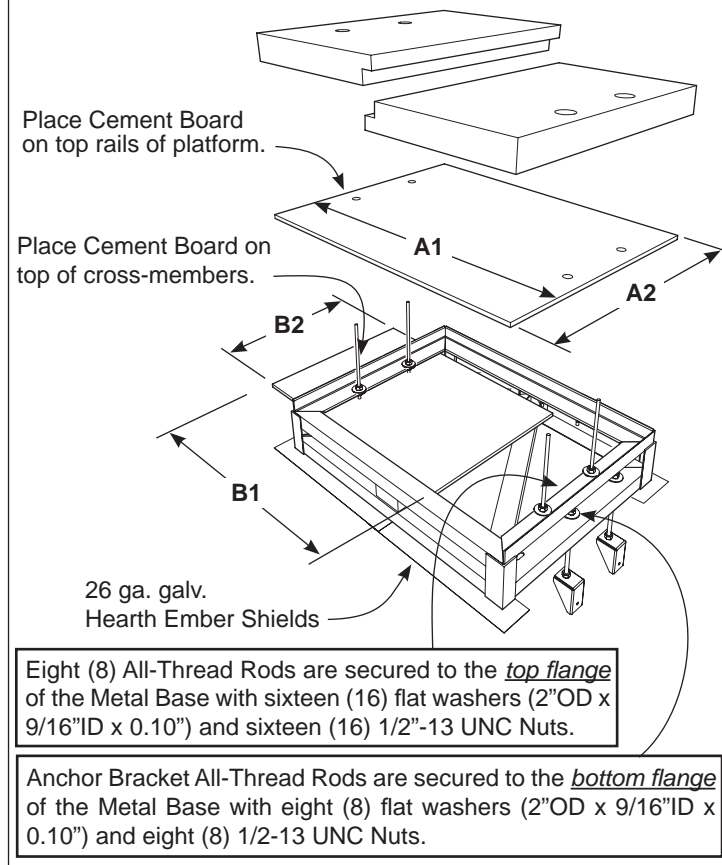

#### ▲ IMPORTANT:

Remember to tighten up nuts below the floor after fireplace installation in order to take up any slack in the threads.

### Hearth Ember Shield:

Metal safety stripping is required between the front of the Fireplace Hearth and Hearth Extension (not supplied). A 26 gauge galvanized 4" wide metal strip can be used. The length needs to extend 2 inches beyond each side of the fireplace opening. If two strips are used, make sure they overlap at least two inches in the middle. The strip is placed about 2" into the underside of the platform at the front of both openings on the fireplace.

Note: When using an on-site-constructed hearth extension, you may use a sand-cement grout between the hearth and extension instead.

## What You Will Need

You will find that the MASON-LITE Fireplace is designed to be completely assembled on-site, consisting of interlocking precast parts. You will need a thin-set type mortar for bonding. The parts of the fireplace are made of Mason-Lite's incredibly strong blend of specialty cement and a light weight aggregate.

**IMPORTANT!** When applying mortar, it is imperative that the concrete blocks be maintained moist (not soaking) so they don't absorb the water out of the mortar and cause adhesion to fail. Frequently run a damp sponge to the parts before mortar is applied!

The installation of an anchor plate/damper is required but not supplied. You may purchase it from any chimney manufacturer or MFI. Also, an optional combustion air inlet MFP4-AK can be obtained from MFI.

Refractory Firebrick Liners also need to be installed. These should be a minimum of 1-1/8" (one and one-eighth inches) thick. The liner will be applied within the walls and hearth area of the firebox.

### Materials needed for concrete slab (non-combustible) installation

- Eight (8) pieces 3/8" rebar x 36" long (included with unit)
- Eight (8) pieces of rebar x 12" long (included with unit)
- Epoxy for securing rebar in footing / foundation
- Three (3) - 90 lb. bags of ready mix concrete with 1/4" or smaller aggregate
- Mason-Lite Mortar (one 50 lb. bag)

### Materials needed for combustible wood floor installation:

- Eight (8) pieces 3/8" rebar x 36" long (included with unit)
- Eight (8) 12" long, 1/2-13 UNC All-Thread with (24) nuts and washers
- 8 inch Metal Base.
- 1" ceramic fiber blanket the size of the hearth base to go under the metal base.
- 1/2" cement boards.
- Four or more fasteners to attach metal base to floor joists
- Mason-Lite Mortar (at least one 50 lb. bag)
- Three (3) - 90 lb. bags of ready mix concrete with 1/4" or smaller aggregate.

### Tools needed for both above installations:

- One 4' level
- Roto-hammer with 1/2" drill bit (needed for concrete slab install only)
- Drill motor with mixer blade (to mix Mason-Lite Mortar)
- Two empty 5 gallon buckets (to mix Mason-Lite Mortar)
- One wheelbarrow and shovel to mix concrete.
- Grout bag
- Triangular masonry trowel
- Rubber hammer
- Sponge and water bucket to wipe down and moisten parts prior to applying mortar.

## Field Assembly Procedures

- a) Mixing the MASON-LITE mortar – The mortar comes premixed and should be dry. Be sure to use clean water and work it up into a mixture that is pasty but not lumpy. If it's too thin and the surfaces don't stay moist, the components will not adhere. Load the mixture into a standard grout bag.
- b) Apply about ½" (one-half inch) thickness of mortar. The mortar bead should be approximately ½" (one-half inch) away from all edges. The mortar has a considerable amount of holding power so do not overload the components with too much mortar. Keep the components moist at all times!
- c) Some mortar will "ooze out" when placing components together, this is normal. Wipe excess away with a trowel. Do not cover component surfaces completely with mortar. Do not apply the mortar in thick bands even if the component you are working with is larger than the rest. You will want to apply "stripes" of mortar in these situations.
- d) Make sure components are level. It's extremely important that you pay careful attention to how you are assembling the Mason-Lite Fireplace since every component builds on the next. If you have to make any kind of an adjustment, do not try to do it "by loading an opening" with mortar, this will only result in a fireplace that will not be plumb or level. Use wood shims instead. **You will find these small wood shims supplied with the Mason-Lite Fireplace** and you can nudge them in between openings to achieve the precision you need in making component adjustments. Once you have inserted any shims, you will want to cover any gaps that may have resulted with the mortar.

### MFPST-43 Fireplace Assembly

- 1) Place the Mason-Lite Fireplace hearth base on top of your non-combustible floor or metal base. For concrete slabs, supporting floor needs to be rated at ASTM 90.
- 2) a) **Combustible Floor Installations:**  
Mix up a batch of mortar and place hearth slabs on top of cement board which sits on top of the Raised Metal Platform (see Figure 15). All-thread rods should stick up through the holes on the hearth slabs.
- b) **Non-combustible Floor Installations:**  
Draw an outline of the hearth area based on the dimensions shown in Figure 18. Position Hearth slabs and mark rebar center locations (see Pg. 10, Fig.14). Drill 4 inches into concrete slab and secure the four pieces of rebar with epoxy.

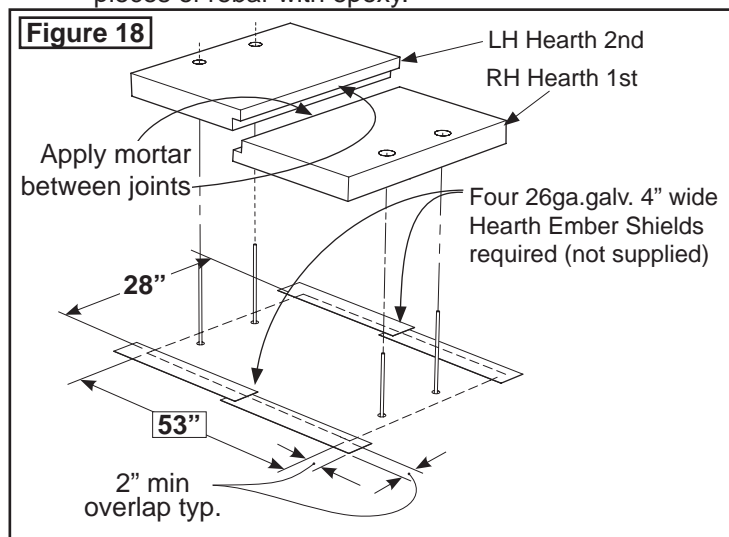

- 3) Before installing the side walls, confirm placement of outside combustion air side block (if required), this can be installed either side depending on which side is accessible to outside combustion air. Prepare side wall footprint with the prepared mortar.

- 4) Keep the assembly of the next sections of the firebox side walls moving up, keeping components moist, mixing mortar as you need it and threading the mortar appropriately as you stack each section, one onto the next. Constantly check for squareness and levelness while building each course of block. As you complete each section, make certain that you adhere the mortar at each and every joint.

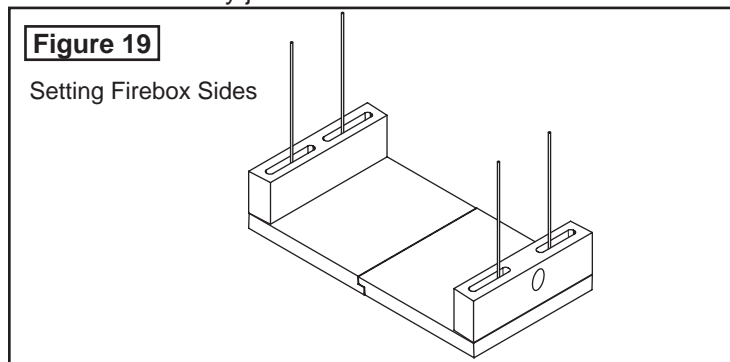

- 5) After the last side walls are in place, add #3 rebar rods and fill the firebox cells with mortar mix. Mix approx. 2 cu. ft. of sanded mortar mix. Put 25% in cells and place #3 rebar vertically into holes on the hearth base. If a raised metal platform was installed, place adjacent to all-thread rods sticking through the cells. Make sure the bars are into the hearth and at least 1/2" (one-half inch) below top of firebox top surface. Finish filling cells.

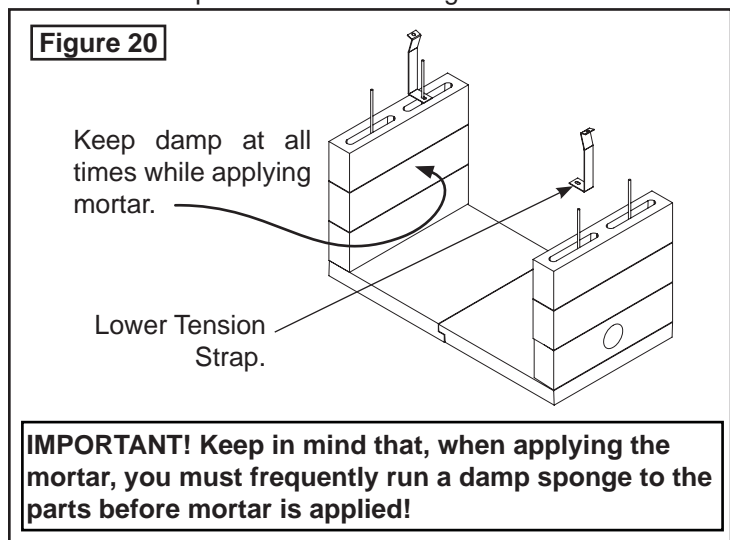

- 6) Set the lintel in place as shown in **Figure 21**. Check that all is level. If you need to make adjustments, use shims. Place one or more of these shims between the lowest wall component and the top surface of the base plate. Once you are satisfied with the degree of levelness, you can address any gap that may have occurred with an appropriate amount of mortar.

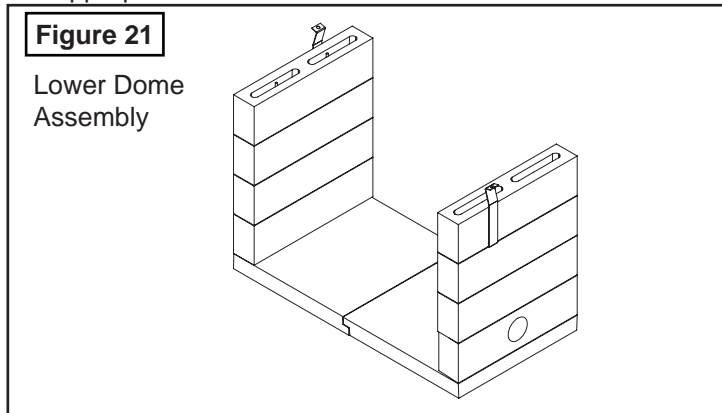

**Note:** Although you are cautioned to use MASON-LITE mortar sparingly because it does have such holding power, you should look over the firebox assembly at the end and fill in any gaps, especially joint connections, with the mortar. Needless to say, you must make adjustments to be sure the fireplace is level and square while the mortar is still wet.

- 7) Set the remaining lintel as shown in **Figure 22**.

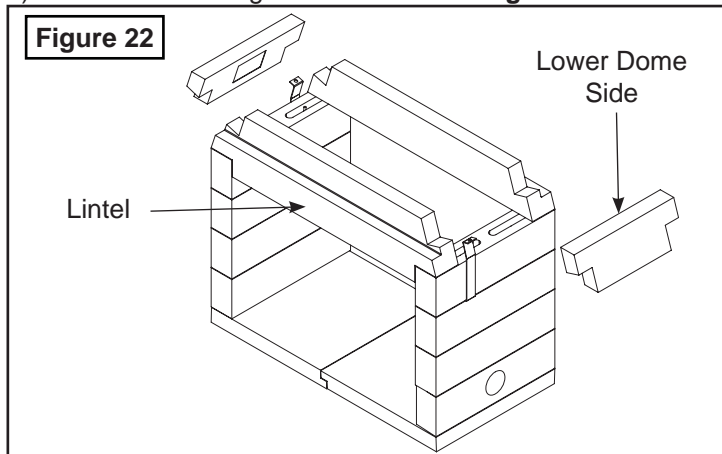

- 8) Now you are ready to start the smoke dome assembly. Take the lower side dome positioned so that the beveled face lines up with the inward angles of the lintel sides (see **Figure 23**). Top surfaces should be level.

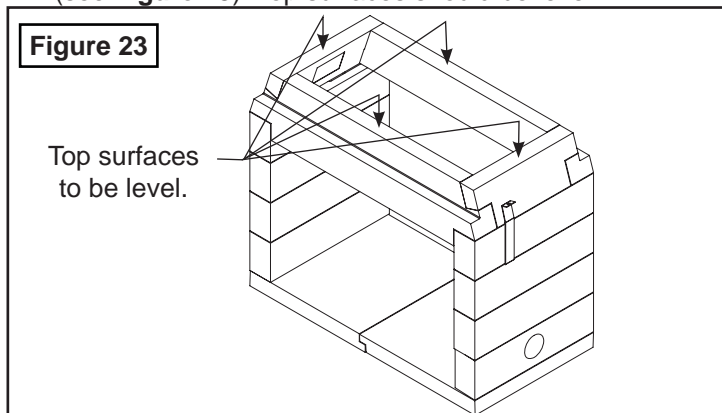

- 9) Now position the front/rear smoke dome parts on top of dome. These parts require care in leveling, noting the

parts have a slight bevel. Check for vertical with level (**Figure 24**).

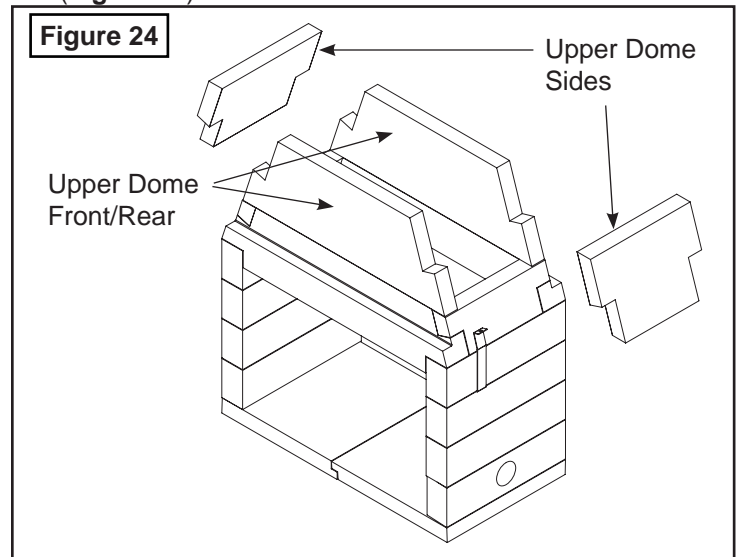

- 10) As you are connecting each MASON-LITE component, be certain you are following the instructions given previously for using MASON-LITE mortar. Stop to look at the smoke dome side, front and rear walls to see that they are aligning correctly and that the surfaces be smooth and uniform. Make sure connections are covered with an adequate amount of mortar. Remember that you have the option of using shims and covering them with mortar if you need to. Make any adjustments to the fireplace alignment before continuing to the next step.

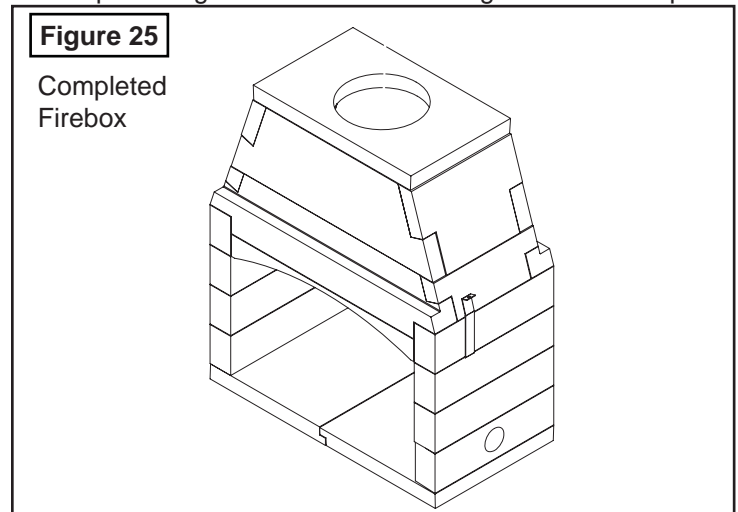

- 11) Check your assembly here. If things are proceeding as they should be, the finished top surface should be flat and level.
- 12) Now you can set the smoke dome top plate into position. Be sure that it is flush in every direction as you place it on the crest of the smoke dome wall assembly.
- 13) Seal Anchor Plate using a 1" thick ceramic fiber blanket. Complete the Anchor Plate assembly by securing with (4) 1/4-inch masonry anchors as shown in **Figure 26**.

**Figure 26a**

**Chimney Anchor Plate Installation**

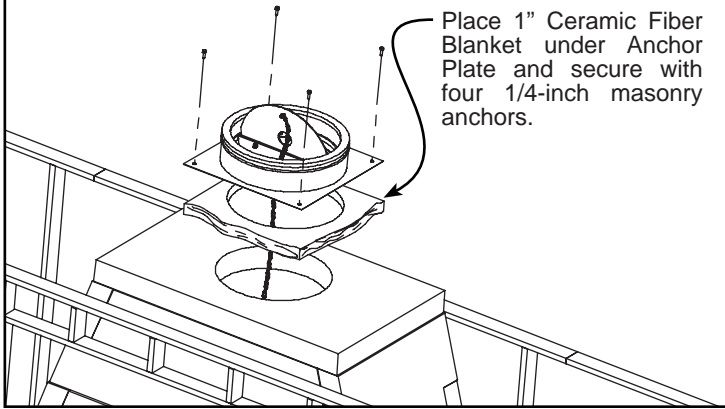

14) Now that you have completed the smoke dome assembly, all the components should stack up for a smooth transition into the flue components. Setting the smoke dome completes the MASON-LITE Firebox and Smoke Dome assembly. You are now ready to begin the installation of the necessary firebrick lining and the flue components.

**Figure 26b**

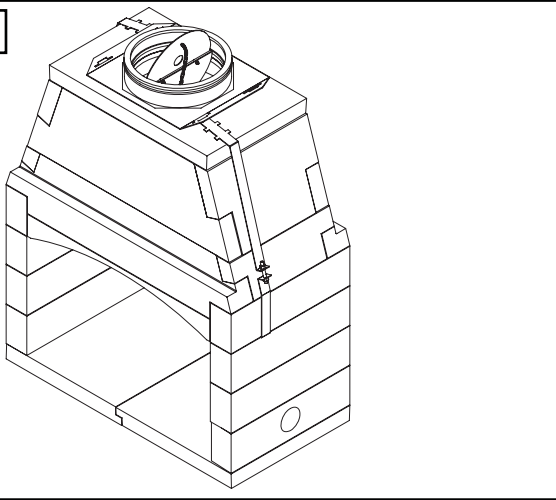

**WARNING: DO NOT PACK REQUIRED AIR SPACES WITH INSULATION OR OTHER MATERIALS.**

## Firestop Radiation Shield

A Firestop Radiation Shield is required in multistory installations at each floor penetration above that where the Support Box is located.

**Figure 27**

**Firestop Spacer with Living Space Above Ceiling**

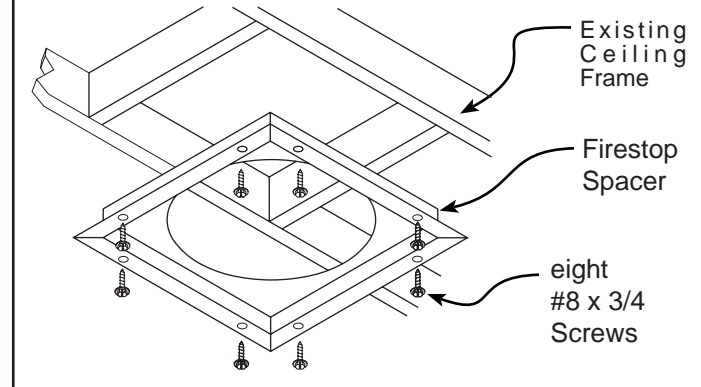

Firestop Radiation Shields also provide complete separation from one floor space to another or attic space as required by most codes. When the double wall pipe passes through a framed opening into an attic space, the firestop must be placed into an attic floor as shown in **Figure 28**.

**Figure 28**

**Firestop Spacer with Attic Space Above Ceiling**

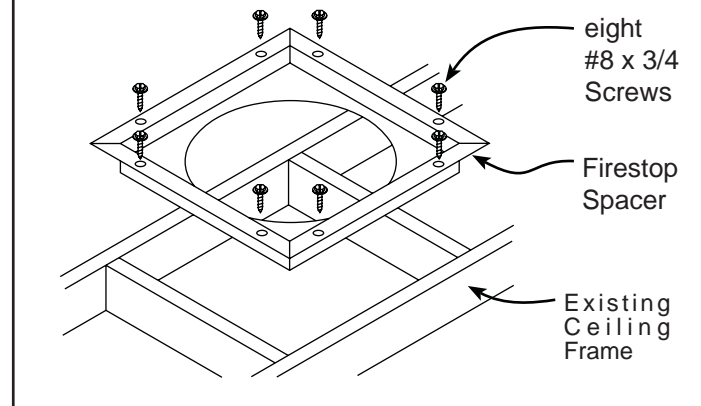

Follow your chimney manufacturer's instructions on specific guidelines pertaining to their chimney and Firestop Radiation Shield installation instructions.

# Mason-Lite Firebrick Liners

## Custom Firebrick Lining

Custom Firebrick lining is not supplied by Masonry Fireplace Industries (MFI). There is, however, the option of **modular** pre-fabricated panels that can be obtained from MFI. See exploded parts page for details.

If custom firebrick lining is desired, 1-1/8" inch thick liners will be required. The pattern for the firebrick lining is exclusively your choice. Before you install the lining, remember to consider any holes your contractor may need to drill for gas, electrical or combustion air kit access holes.

Please use a certified mason to lay-in the brick. He will follow the proper instructions from the fireplace liner manufacturer and also understand the type of adhesive or cement he is to use.

Make sure the fireplace is installed with the finished firebrick floor of the fireplace so that it is at least 11" (eleven inches) above the combustible floor system.

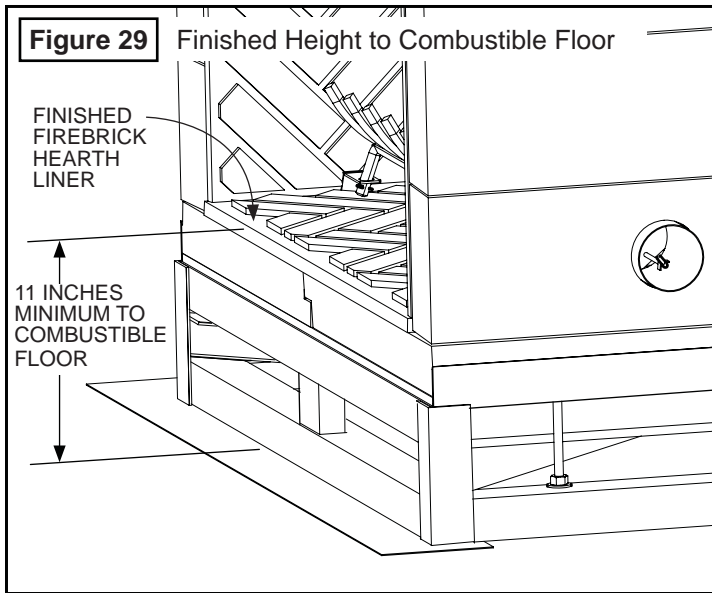

Disclaimer: Masonry Fireplace Industries wishes to express that as the manufacturer of Mason-Lite Fireplaces, they cannot take any liability or responsibility for the way the firebrick or the firebrick mortar performs. It is not unusual in the course of the life of the firebrick, or the firebrick mortar, for heat stress cracks to appear. MFI cannot be responsible for this and other wear and tear to the firebrick and mortar.

## Modular Firebrick Lining

If using our Mason-Lite Firebrick Liners, simply use an extra bucket of the mortar we supply. Install Hearth Liner first, then continue with sides. Consider if brackets for grates will be required also if pre-drilling is required for gaslines, electrical or if the outside combustion air kit is to be installed. If the optional Arch is used, the top corners of the firebrick side liners will need to be notched (see **Figure 30**).

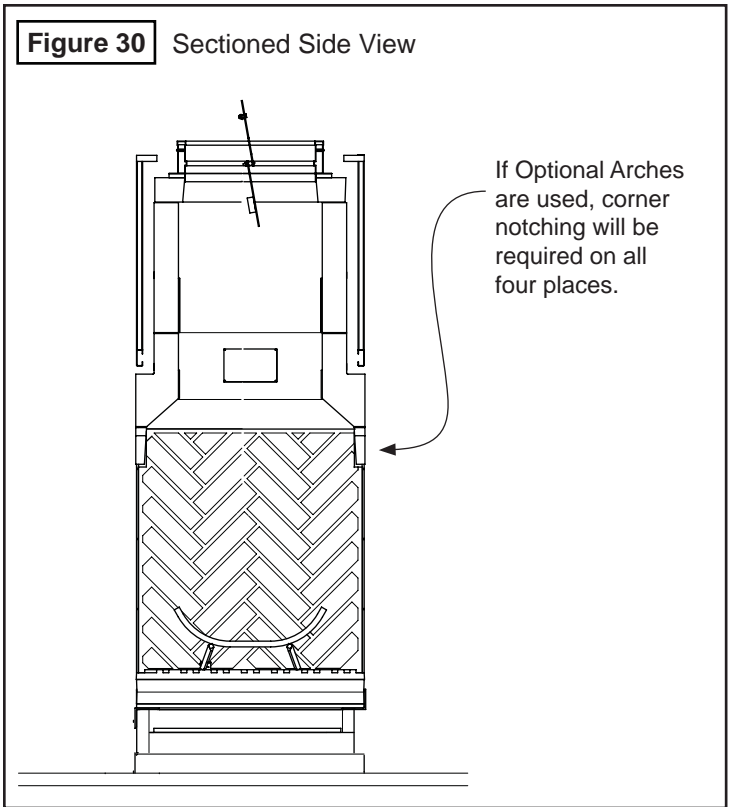

The following Firebrick Liners are available from MFI:

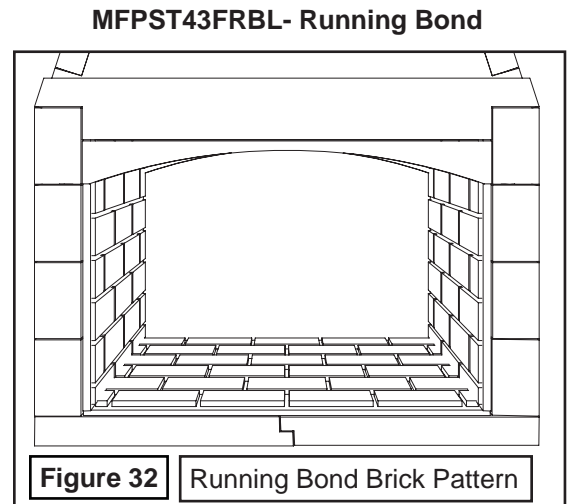
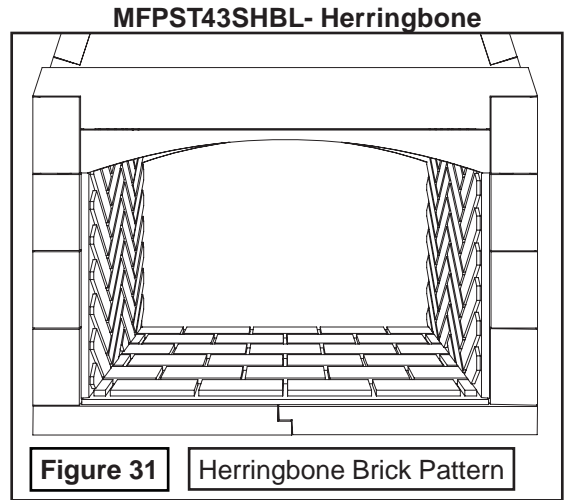

## Fireplace Finishes & Combustible Trim Clearances

Hearth Material & Dimensions – Codes are strict regarding the use of proper materials for hearth extensions and the proper dimensional characteristics.

All hearth extensions must be made of code-rated, noncombustible materials such as tile, brick, concrete or stone. MASON-LITE Fireplaces usually have an opening of approximately 8 sq. ft. (eight square feet) that translates to a hearth extension of about 20" (twenty inches) at the fireplace's opening and about 12" (twelve inches) extension at each side. These relative dimensions are also covered by code. Note that it is required that metal safety strips must be laid on the floor of the non-combustible raised platform. These should be 26 gauge and measure 4" (four inches) wide. They need to extend half way under the platform and half way under the hearth extension material (see Figure 18).

**Attention:** You will note that there will be a gap between the fireplace front and the extension of the non-combustible hearth material. Be certain that you seal this with non-combustible material.

## Mantle and Mantle Shelf Clearances

As with any radiant heat fireplace, all MASON-LITE Fireplaces must comply with building code safety clearances, for units that have openings of 6 sq. ft. (six square feet) or greater.

For Mantel clearances see Figure 9.

Walls that Adjoin – your fireplace cannot be installed closer than 2 ft. (two feet) to any adjoining walls in the room where the fireplace is.

Caution in Regards to Combustibles – If any part of the fireplace or objects in the room (curtains, rugs, paint, cushions, etc.) start to show warping or discoloration due to heat from the fireplace, it is time to take immediate action. Do not use the fireplace until you have figured out how to address the problem. You are facing a potential fire hazard. MFI cannot be responsible for the make-up of material on the exterior of the fireplace you have chosen, nor can MFI be held responsible for the materials in a room that may be responding negatively to heat. However, in almost all cases, there is a solution to the problem, either by making adjustments to airflow or the modifications to the room itself.

## Installing Outside Combustion (make-up) Air

1) The Mason-Lite Fireplace needs enough make-up air to function properly and some local building codes may require outside combustion air to be provided. If no make-up air is provided, improper flue drafting may occur, creating negative pressure whereby smoke may enter the home, especially in homes that are very well insulated and tightly sealed. Check local building codes for specific requirements.

2) Install Combustion Air Kit MFP4-AK into the MASON-LITE Firebox through the side wall opening provided. The tubing that goes out of the firebox wall must feed into a flexible metal conduit as the source for outside combustible air. It can go straight out through an outside wall or into a ventilated crawl space. If crawl space is used, check codes for proper termination.

3) Be sure that you carefully check the source of the outside air before you choose the site for your air intake. You don't want a place where snow will collect, where bushes or trees will be growing or a location that is too close to any other structure.

4) Install a screened termination cap to keep out animals.

## Adding a Gas Pipe

You may elect to add a vented decorative gas appliance (gas log) to your Mason-Lite Fireplace. If so, follow the installation instructions from the Decorative Gas Appliance manufacturer. Familiarize yourself with requirements for installation as outlined by the National Fuel Gas Code, ANSI Z223.1. This gas pipe provision should only be used on a decorative gas appliance.

1) You can route the gas piping practically anywhere in the firebox – the floor, back wall or side walls. You will just need a masonry drill; the instructions from the gas appliance manufacturer will be very straightforward.

2) Fill in the holes you have drilled around the gas piping with the regular MASON-LITE mortar.

3) Follow the Gas Log manufacturer's instructions.

## Adding Electrical Connection

Like the gas line, electrical feed lines can be run through the floor, back wall, or side walls. Follow local building and electrical code requirements.

## MASON-LITE Chimney Systems:

The Mason-Lite Fireplace requires the following chimney systems:

All chimney systems must be installed with an integrated damper/base plate installed on top of unit. Installers are cautioned to put the chimney system together exactly as instructed and shown in chimney manufacturer's guide. Any variations may have serious consequences resulting in an accident or malfunction. If instructions are not followed, the warranty on the product will become null and void.

Note that the most important aspect of the installation is maintaining the minimum required clearances to combustible materials according to the chimney pipe manufacturer's recommendations, otherwise a potential fire hazard may occur.

Warning: do not interchange chimney manufacturer's parts with any other parts except those specifically required by the chimney manufacturer's recommendations otherwise a potential hazardous condition may be created.

Attention: When choosing a Chimney System it must meet the following requirements:

- Designed for installation in accordance with the National Fire Protection Standard and UL 103.
- Meets the requirements of NFPA 211.
- Designed in accordance with ICC Codes.

Assuming you have sections of vertical pipe that are more than 10' (ten feet) measuring between elbows, you must insert – at midpoint – a chimney stabilizer. When installing the stabilizer, pull out the support straps with a good amount of tension and hammer to the frame.

### Installing Damper and Chimney System

The Damper System/Anchor Plate assembly is required for the installation of these chimney systems. Consult the Chimney System manufacturer's instructions.

1. Using the Damper/Anchor Plate Assembly, apply a 1/4" (one-quarter inch) bead of gasket cement around the base of the Anchor Plate. Apply ceramic blanket gasket to the gasket cement.
2. Apply balance of gasket cement in a 1/4" (one-quarter inch) bead on top of smoke dome top approx. 3" (3 inches) outside of outlet hole. Install damper on top of unit pressing damper into cement.
3. Place chimney adapter onto top of damper plate and center in opening using gasket supplied with adapter.
4. Attach adapter with (12) #8 cement fasteners supplied, carefully drilling holes into damper plate.
5. Attach damper chain stop on center rear of lintel 3" (three inch) vertical from opening using (3) #8 cement fasteners.

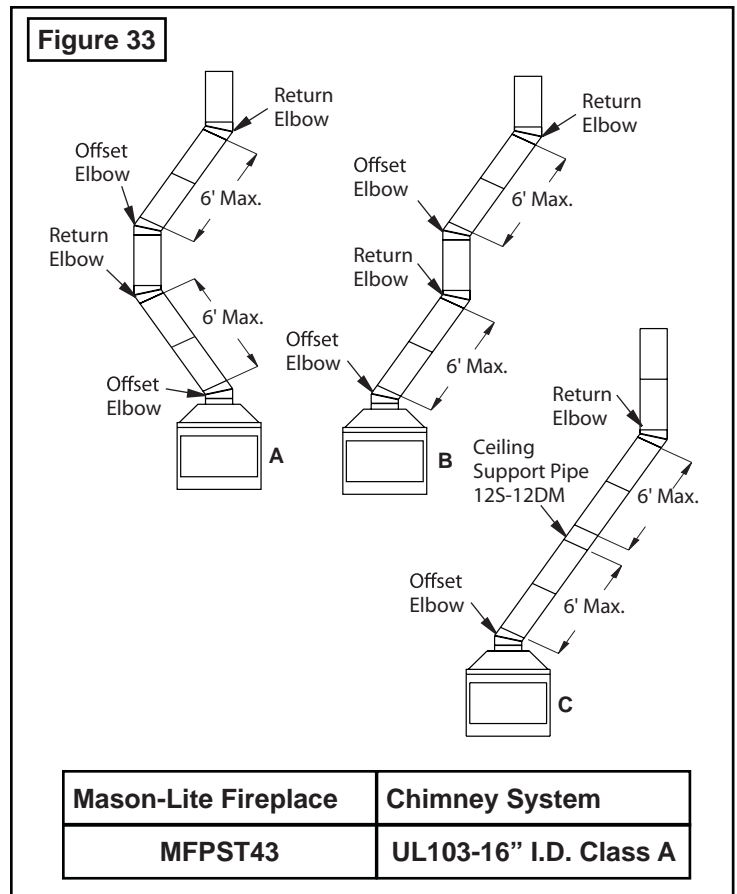

**Attention:** Clearance to combustible construction cannot be reduced during course of construction. For the safe operation of the finished fireplace, these clearances must be followed when building the framework for the chimney system.

### Finishing Your Installation

To complete your fireplace installation, a fireplace grate will be required for safe operation. The fireplace grate must be sized to 50% of the hearth maximum. Additionally, a fireplace screen must be installed for safety.

### Fireplace Door Accessory

**IMPORTANT:** Only Crown-Breckinridge or McKenzie-Pendelton Doors are approved for use with this fireplace. For installation Instructions, see separate instructions included with doors.

## Mason-Lite Owner's Operation & Precautions

Installers of the Mason-Lite are urged to leave the owner's manual with the unit after installation is complete.

**WARNING:** Do not attempt to operate your fireplace without a fire safety screen installed.

**CAUTION:** The manufacturer cautions against using chemical chimney cleaners. Never use charcoal or coal in the fireplace under any circumstances.

- 1) First Lighting of the Mason-Lite – After construction is completed, all elements of the fireplace and chimney system must be completely dry. This means that the unit must stand without any firing for a minimum of 28 days. Only after that period of time can a first lighting take place. The first fire must be small and well-controlled, started with a small amount of kindling. Add no more than eight pounds of wood, preferably small logs not more than 3" (three inches) in diameter. You will probably burn no more than three to four of these small logs. Do not let the fire burn for more than one hour. After this first lighting – when the fireplace has started to "cure" Do not set another fire for at least 24 hours.
- 2) Second Lighting – Start the fire slowly and gradually as you did with the first lighting, but this time you can burn up to ten pounds of firewood, probably four to five logs that are 3" (three inches) in diameter. With the second lighting you can let the fire burn two hours – no more.
- 3) After First and Second Lightings – When the fireplace has been properly cured with 1st and 2nd lightings, you will be able to add a full fuel load to the MASON-LITE which is about 10 to 15 pounds of firewood at any given time. Consider that this typical fuel load is three to four dry hardwood logs that are about 6" (six inches) to 8" (eight inches) in diameter.
- 4) Without a grate for your firewood to rest on, you cannot get the air flow you need under the fire which makes for a hotter, more satisfying fire.
- 5) Don't "over burn" – Always remember, your Mason-Lite Fireplace is an elegant addition to your home. It is not an indoor incinerator! If you start to use the fireplace and begin a routine of "over burning," you can permanently and unalterably damage the unit.  
Under no circumstances should you be burning household trash, including chemicals and combustibles, cardboard boxes, your office papers, scrap lumber or stray branches from your yard, particularly pine.

**WARNING:** Burning of above mentioned materials will cause an unsafe condition and will void your warranty!

## Starting a Fire and Basic Operation

Before starting a fire in your fireplace, open the damper to its' fully open position. Crumple some paper and place it on the log grate. Use some soft, dry wood as kindling and put it on top of the paper. Place some small logs or split logs atop the paper and kindling.

Finish off the fuel load with a couple of hardwood logs or split logs – oak or hickory. Check to see that you're stacking the logs so that they will fall inside the grate as they burn.

To get the most out of your wood, it is recommended that you let it set and completely dry out for nine months to a year.

When you are satisfied with the arrangement of your wood load, light the paper which in turn will ignite the kindling, then the softer wood and finally, the harder wood logs. As the fire burns, you can carefully lay additional logs on the flame, but make sure you place them gently without forcing them into the opening.

## **ANNUAL FIREPLACE MAINTENANCE**

Your fireplace and chimney require seasonal and monthly tune-ups". Like any piece of well-built equipment, the Mason-Lite Fireplace and chimney needs routine maintenance.

The manufacturer recommends that inspection of the fireplace and chimney take place on a monthly basis during the heating season.

Start at the top, looking for birds' nests, leaves or any other obstructions. Also check the spark arrestor, for creosote or soot build-up. Twice a year, you will want to clean the firebox and chimney yourself or hire a professional chimney sweep to do the job for you. If you elect to do it yourself, use a plastic, wood or steel brush for the inside of the chimney.

For the spark arrestor, scrub with a wire brush. To dismantle the chimney cap for cleaning of the flue, unscrew the four screws that hold it in place. For cleaning access from below, open the damper in the firebox. It is best to use a flexible handle chimney cleaning brush made especially for the job.

If your fireplace system has any offset chimney sections, start cleaning with the flexible brush from the top of the section downward to the elbow. Then clean from the firebox up to the offset/return section.

Be sure that you have covered the floor of the fireplace and out to the hearth with a damp sheet that has been taped securely in place. When all the soot has settled, remove the sheet and vacuum up – don't sweep the excess soot.

Good old-fashioned "elbow grease" is enough to remove the extraneous matter from the inside of the firebox and chimney. Never use any chemical cleaners as their residue could introduce a fire hazard after the task is completed.

Outside Inspection – During your once a month inspection of the firebox and chimney, make it a point to also check the outside of the chimney, the metal flashing and weather seals that surround it. If you find any cracks or openings around screws or nails, seal them to avoid any roof or chimney chase leaks.

## **SURFACE CRACKS**

The MASON-LITE FIREPLACES are manufactured using high quality materials. During the drying process, surface cracking may occur. These small cracks (under 1/16" will not effect the fireplace safety or performance). During the assembly process, fill surface cracks with thin-set mortar and brush when drying for a smooth surface finish.

Removal of Creosote and Soot Formation – Creosote vapors are known to form in the relatively cool chimney flues of slow burning fires, hence, creosote residue collects on the flue lining. Because of soot and creosote build-up, it is recommended that the fireplace and chimney cleaning be done twice a year. In colder climates, cleaning should be done more often.

Always allow the fireplace to completely cool before you work on it, which means, of course, shutting off all gas and electrical connections, also.

Be certain that you use only solid fuel in your fireplace. You may use a natural or LP gas log lighter as a method to start your wood fire.

The flue damper must be in the OPEN position whenever there is heat in the fireplace.

## **CUSTOMER SERVICE & PARTS REPLACEMENT:**

Parts and accessories may be purchased from your local dealer. Additional information is available from Masonry Fireplace Industries,.LLC.

Accessory orders will be accepted by mail, or you may call your order in Monday through Friday from 8:00 a.m. to 5:00 p.m. (Pacific Standard Time) at: (800)-345-7078.

## Appendix I

For installations regulated by the International Residential Code, the support foundation for the fireplace installed on concrete shall consist of a minimum of 6 inches thick reinforced concrete slab. The minimum specified compressive strength of  $f'_c$ , shall be as required in Table R402.2 of the International Residential Code (IRC). Concrete subject to moderate or severe weathering as indicated in Figure R301.2(3) of the International Residential Code (IRC) shall be air entrained as specified in Table R402.2 of the International Residential Code (IRC). The maximum weight of fly ash, other pozzolans, silica fume, slag or blended cements that is included in concrete mixtures for garage floor slabs and for exterior porches, carport slabs and steps that will be exposed to deicing chemicals shall not exceed the percentages of the total weight of cementitious materials specified in Section 4.2.3 of ACI 318. Materials used to produce concrete and testing thereof shall comply with the applicable standards listed in Chapter 3 of ACI 318.

For installations regulated by the International Building Code (IBC), the support foundation for the fireplace installed on concrete shall consist of a minimum of 6 inches thick reinforced concrete slab. The concrete strength and durability shall comply with Sections 1903, 1904 and 1905 of the International Building Code (IBC).

**TABLE R402.2 MINIMUM SPECIFIED COMPRESSIVE STRENGTH OF CONCRETE**

| <b>TYPE OR LOCATION OF CONCRETE CONSTRUCTION</b>   | <b>MINIMUM SPECIFIED COMPRESSIVE STRENGTH<sup>a</sup> (<math>f'_c</math>)</b> |  |
|--|---|--|
|  | <b>Negligible</b>   | <b>Moderate or Severe Weathering Potential<sup>b</sup></b> |
| Basement walls, foundations and other concrete not exposed to the weather                                | 2,500   | 2,500 <sup>c</sup>   |
| Basement slabs and interior slabs on grade, except garage floor slabs                                    | 2,500   | 2,500 <sup>c</sup>   |
| Basement walls, foundation walls, exterior walls and other vertical concrete work exposed to the weather | 2,500   | 3,000 <sup>d</sup>   |
| Porches, carport slabs and steps exposed to the weather, and garage floor slabs                          | 2,500   | 3,000 <sup>d,e,f</sup>                                     |

- a. Strength at 28 days psi.
- b. See Figure R301.2(3) for weathering potential.
- c. Concrete in these locations that may be subject to freezing and thawing during construction shall be air-entrained concrete in accordance with Footnote d.
- d. Concrete shall be air-entrained. Total air content (percent by volume of concrete) shall be not less than 5 percent or more than 7 percent.
- e. See Section R402.2 for maximum cementitious materials content.
- f. For garage floors with a steel troweled finish, reduction of the total air content (percent by volume of concrete) to not less than 3 percent is permitted if the specified compressive strength of the concrete is increased to not less than 4,000 psi.

## Appendix II

**FIGURE R301.2(3) WEATHERING PROBABILITY MAP FOR CONCRETE**

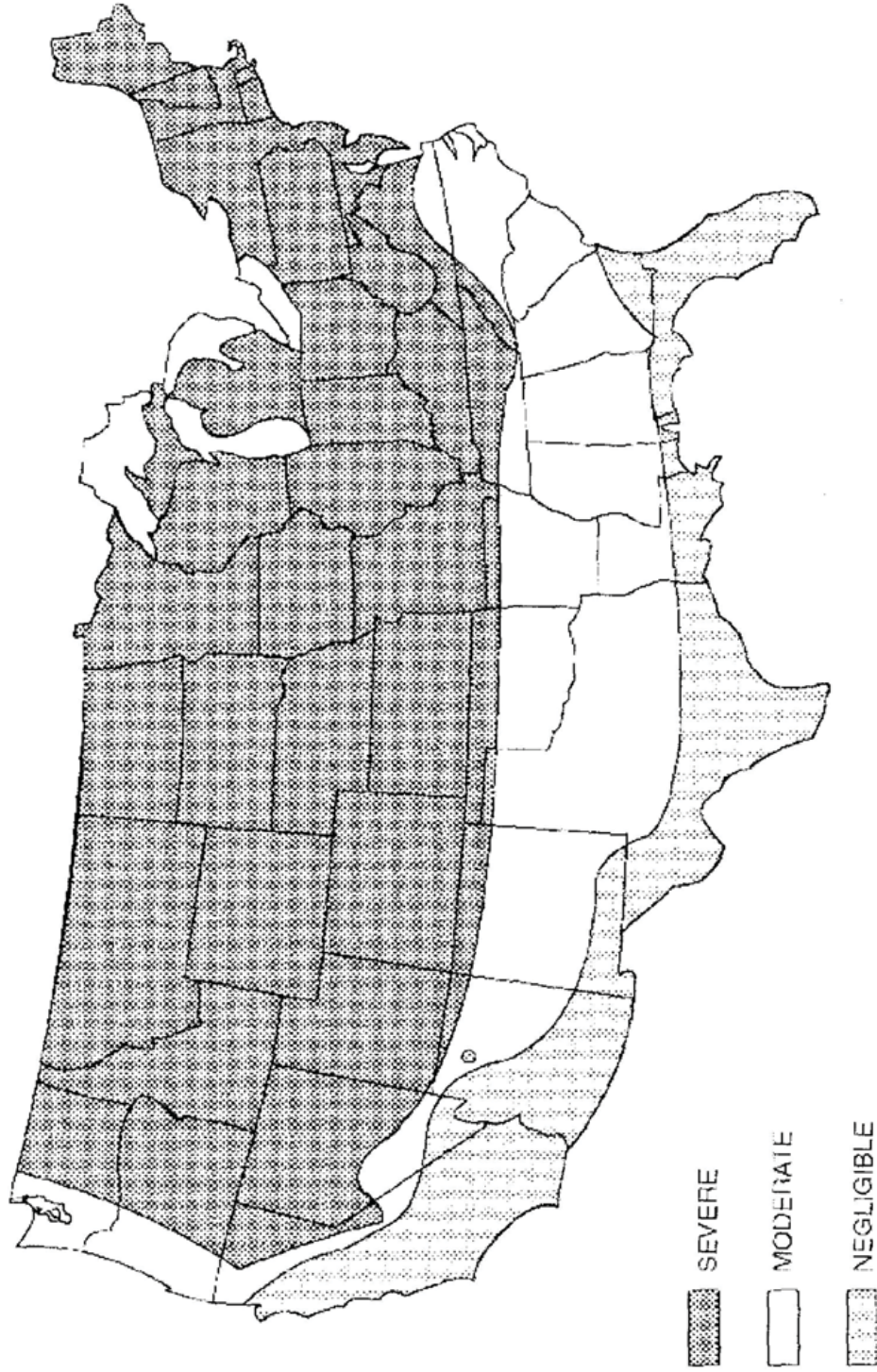

- Alaska and Hawaii are classified as severe and negligible, respectively.
- Lines defining areas are approximate only. Local conditions may be more or less severe than indicated by region classification. A severe classification is where weather conditions result in significant snowfall combined with extended periods during which there is little or no natural thawing causing deicing salts to be used extensively.

## Limited Warranty Mason-Lite™ Fireplace

Masonry Fireplaces Industries, LLC (MFI) warrants all MASON-LITE Fireplaces to be free from defects in materials that adversely affect fireplace performance for a period of ten (10) years from the date of purchase, subject to the terms and conditions of this limited warranty. MFI does not warrant accessory chimney, outside air ducts, gas control or burner system, ceramic logs, and devices not manufactured by MFI. Valves and electronic parts are only covered for one year parts and labor per the log set manufacturer's warranty.

This warranty covers only products manufactured by MFI, specifically the modular concrete firebox, and NO WARRANTY, EXPRESS OR IMPLIED, EXTENDS TO ANY OF THE HARDWARE, FOUNDATION, VENTING, DUCTS, OR ACCESSORIES. THIS WARRANTY DOES NOT COVER DRAFTING, SMOKING, OR SOOTING OF THE FIREPLACE SYSTEM. Factors beyond the manufacturer's control may affect drafting, smoking, and sooting, MFI cannot guarantee these aspects of performance.

If a component is found to be defective under the terms of this warranty, the party this warranty is extended to shall notify MFI, 315 W. 3rd Street, Santa Ana, CA 92701 in writing, by registered mail, within thirty (30) days following the discovery of the defect within the warranty period. The letter shall contain (1) the date of purchase; (2) place of purchase; (3) address of installation; (4) name, address and phone number of the homeowner; and (5) a brief description of the defect.

MFI, or any entity thereof, is not responsible for any labor costs or indirect costs incurred for the replacement of defective components.

MFI is not responsible for misuse or mishandling of component parts. Nothing in this warranty makes MFI, or any entity thereof, liable in any respect for any injury or damage to the building or structure in which the fireplace has been installed or to the persons or property therein arising out of the use, misuse, or installation of properly manufactured MFI product.

MFI, OR ANY ENTITY THEREOF, SHALL NOT BE HELD LIABLE FOR ANY INCIDENTAL OR CONSEQUENTIAL DAMAGES OR EXPENSES ARISING OUT OF THE USE OF THE FIREPLACE. ALL SUCH DAMAGES AND EXPENSES ARE HEREBY EXCLUDED.

This warranty is null and void when the fireplaces are not installed pursuant to the installation instructions provided by MFI and local building codes have not been followed completely.

This warranty applies only to those fireplaces installed in the continental United States, Hawaii, Alaska and Canada. If any part of this warranty is found to be unenforceable,, the remaining parts shall remain in force and effect.

MFI HEREBY DISCLAIMS ALL GUARANTEES AND WARRANTIES, EXPRESS OR IMPLIED, BEYOND THE WARRANTIES SET FORTH HEREIN.

### CUSTOMER SERVICE & PARTS REPLACEMENT:

Parts and accessories may be purchased from your local dealer. Additional information is available from Masonry Fireplace Industries, L.L.C. Accessory orders will be accepted by mail, or you may call to order Monday through Friday from 1:00 p.m. to 5:00 p.m. (Pacific Standard Time) at: (800) 345-7078.

Please complete the following information for future reference and warranty verification:

**Date of Purchase** \_\_\_\_\_ **20** \_\_\_\_\_

**Model #** \_\_\_\_\_

**Serial #** \_\_\_\_\_