

# ICC-ES Evaluation Report

**ESR-2401\***

Issued September 1, 2008

*This report is subject to re-examination in one year.*[www.icc-es.org](http://www.icc-es.org) | (800) 423-6587 | (562) 699-0543

A Subsidiary of the International Code Council®

**DIVISION: 10 00 00—SPECIALTIES**  
**Section: 10 31 00—Manufactured Fireplaces****REPORT HOLDER:****MASONRY FIREPLACE INDUSTRIES, LLC**  
315 WEST 3RD STREET  
SANTA ANA, CALIFORNIA 92701  
(800) 345-7078  
[www.mason-lite.com](http://www.mason-lite.com)**EVALUATION SUBJECT:****MASON-LITE MODULAR CONCRETE FIREPLACES****ADDITIONAL LISTEE:****FMI PRODUCTS, LLC**  
2701 SOUTH HARBOR BOULEVARD  
SANTA ANA, CALIFORNIA 92704**1.0 EVALUATION SCOPE****Compliance with the following codes:**

- 2006 *International Building Code*® (IBC)
- 2006 *International Residential Code*® (IRC)

**Properties evaluated:**

- Fire resistance
- Seismic resistance

**2.0 USES**

The Mason-Lite™ modular concrete fireplaces, Models MFP-39, MFP-44 and MFP-49, are fireplaces that are constructed in the field using prefabricated concrete firebox components with factory-built chimneys. The fireplaces are for use only with solid wood logs, LPG or natural gas log lighters, and decorative gas logs complying with ANSI Z 21.60.

**3.0 DESCRIPTION****3.1 Fireplace Units:**

The Mason-Lite™ Masonry Fireplace is a modular refractory masonry unit designed for field assembly. The firebox is constructed using precast, interlocking refractory blocks secured to each other using Mason-Lite mortar. The system is supplied with all parts necessary for the assembly of a complete masonry firebox unit. Refer to

Figures 1 and 2 for illustrations of Mason-Lite system components. For combustible floor installations, the Mason-Lite system includes a noncombustible raised platform designed to be placed beneath the field-assembled firebox unit. High-temperature refractory brick, 1<sup>1</sup>/<sub>8</sub> inches (28.6 mm) thick, is required to line the interior of the firebox.

The MFP-39, MFP-44 and MFP-49 are also sold as FMI Products, LLC, models MM39, MM44 and MM49, respectively.

**3.2 Chimneys:**

The firebox units may only be used in conjunction with specific chimney systems. The MFP-39 and MFP-44 fireplaces require the use of a Desa/FMI DM12 12-inch chimney or 12- or 14-inch flue system listed by an approved agency as complying with UL103. The MFP-49 fireplace requires a 14-inch flue system listed by an approved agency as complying with UL103. The chimneys are limited to a maximum height of 40 feet (12 192 mm) and a minimum height of 14 feet (4267 mm); except that, where offsets are used, the minimum height is 17 feet (5181 mm). A maximum of two offsets are permitted.

**3.3 Grout and Mortar:**

The grout and mortar used to construct the fireplace is provided by Masonry Fireplace Industries, LLC.

**4.0 DESIGN AND INSTALLATION****4.1 General:**

The fireplace units must be installed in accordance with this report, the manufacturer's instructions and the applicable code. A copy of the manufacturer's instructions must be available at the jobsite at all times during installation.

**4.2 Design:**

When installed in accordance with Section 4.3 of this report and the manufacturer's instructions, the fireplace units may be installed in Seismic Design Categories A through F. In Seismic Design Categories D, E and F, the seismic design parameters are limited to the values noted in Table 2. The seismic design must be in accordance with Sections 13.3, 13.4, 13.5 and 13.6 of ASCE 7.

Structural design calculations and construction plans prepared by a licensed design professional are required to determine the requirements for the fireplace foundation and anchorage of the fireplace to the foundation.

**\*Revised October 2010**

When installation is on wood floor construction, the licensed design professional shall determine the requirements for support and anchorage for the combined gravity and seismic loading. The applicability of the seismic design parameters in Table 2 must be verified with due consideration of the flexibility of anchorage and supports. In addition, the calculated long-term deflection of the wood members supporting the fireplace shall not exceed the values shown in IBC Table 1604.3 for floor members. Under the IRC, an engineered design must be provided in accordance with IRC Section R301.1.3.

#### 4.3 Installation:

The Mason-Lite™ Masonry Fireplace system may be installed directly on concrete slabs and footings or on combustible floors, subject to the structural design limitations contained within this report. For concrete foundations, the firebox base is installed directly to the foundation. For combustible supporting systems, installation of a 1-inch-thick (25.4 mm) ceramic fiber-board, 6-inch-high (152 mm) metal support base and 1/2-inch-thick (12.7 mm) cement board is required before placement of the firebox hearth components. The precast components are assembled following the Mason-Lite published instructions and using Mason-Lite mortar. Minimum No. 3 reinforcing bar or 1/2-inch-diameter (12.7 mm) all-thread must be installed, and the cells of the precast components are grouted with Mason-Lite grout. Anchorage of the fireplace unit to the foundation or supporting floor must be designed as described in Section 4.2.

After completion of the construction of the lower firebox components, the precast lintel and firebox dome components are installed. In Seismic Design Categories D, E and F, straps must be installed as shown in Figure 3. The chimney anchor plate is then attached to the firebox dome as shown in Figure 4. Once the installation of the chimney anchor plate is completed, the listed prefabricated chimney flue pipe is installed as shown in Figures 5, 6 and 7. The clearances to combustibles are as required in Table 4. Installation of the chimney must be in accordance with the chimney's listing and the chimney manufacturer's instructions.

Firebrick lining having a minimum thickness of 1 1/8 inches (29 mm) must be installed along with any required hearth extensions as shown in Figure 8. The fireplace units are not recognized for use with doors.

Combustion air must be provided in accordance with Chapter 17 of the IRC or Chapter 7 of the 2006 *International Mechanical Code*®.

## 5.0 CONDITIONS OF USE

The Mason-Lite modular concrete fireplaces described in this report comply with, or are suitable alternatives to what is specified in, those codes listed in Section 1.0 of this report, subject to the following conditions:

- 5.1 The fireplaces are installed in accordance with this report and the manufacturer's published installation instructions. In the event of a conflict between this report and the manufacturer's instructions, this report governs.
- 5.2 The fireplace units must be installed by contractors approved by Masonry Fireplace Industries, LLC.
- 5.3 The foundation or supporting structure and the anchorage of the fireplace unit to the foundation or supporting structure must be designed for all applicable loads, including gravity, wind and earthquake loading, and must include applicable load combinations in accordance with IBC Section 1605. The weights of the various components and the footprint of the installed unit are included in Table 1. The structural design and calculations must be prepared by a registered design professional and must be provided to the code official for approval.
- 5.4 The fireplace units are manufactured in Highland, California, under a quality control program with inspections by PFS Corporation (AA-652).

## 6.0 EVIDENCE SUBMITTED

Data in accordance with the ICC-ES Acceptance Criteria for Field-constructed Fireplace Systems Using Prefabricated Blocks (AC375), dated June 2007.

## 7.0 IDENTIFICATION

The components of the fireplace units, including mortar and grout, are supplied to the jobsite on a factory-assembled, shrink-wrapped pallet bearing a label with the company name (Masonry Fireplace Industries, LLC, or FMI Products LLC) and address; the product name; the address of the manufacturing plant; and the evaluation report number (ESR-2401). A permanent label must be attached to the installed fireplace by the contractor, identifying the Masonry Fireplace Industries, LLC, name; the product name; the manufacturing location; the date of manufacture and the serial number; the clearances to combustibles; other information required by UL 127; the inspection agency name (PFS Corporation); and the evaluation report number (ESR-2401).

**TABLE 1—MASON-LITE FIREPLACE WEIGHTS AND FLOOR AREA**

<b>MFI Model</b>	<b>MFP-39</b>	<b>MFP-44</b>	<b>MFP-49</b>
<b>FMI Model</b>	<b>MM39</b>	<b>MM44</b>	<b>MM49</b>
Fireplace	1,110 lbs	1,230 lbs	1,320 lbs
Damper/Anchor Plate, Firebrick, Grout & Mortar	350 lbs	350 lbs	350 lbs
Steel Platform	80 lbs	80 lbs	80 lbs
Chimney	50 lbs/lineal ft	50 lbs/lineal ft	50 lbs/lineal ft
Floor Area	42 in. x 28 in. (8.12 ft <sup>2</sup> )	48 in. x 28 in. (9.33 ft <sup>2</sup> )	53 in. x 28 in. (10.30 ft <sup>2</sup> )

For **SI**: 1 lb = 4.45 N, 1 in. = 25.4 mm, 1 lb/lineal ft. = 0.0146 N/mm, 1 ft<sup>2</sup> = 0.092 mm<sup>2</sup>.

**TABLE 2—SEISMIC DESIGN PARAMETERS**

Amplification factor, $a_p$	1.0
Component response modification factor, H.	1.5
Height in structure of point of attachment of component, Z with respect to the base, feet	1
Average roof height of structure with respect to the base, h, feet	10
Fundamental period of the fireplace, $T_p$	0.111
Spectral response acceleration parameter, $S_{Ds}$	0.7

**TABLE—3 DEFLECTION LIMITS**

<b>CONSTRUCTION</b>	<b>L</b>	<b>S or W</b>	<b>D + L<sub>1</sub></b>
Floor members	l/360	---	l/240

<sup>1</sup>For wood structural members having a moisture content of less than 16 per cent at time of installation and used under dry conditions, the deflection resulting from L + 0.5D is permitted to be substituted for the deflection resulting from L + D. (Note: this table has been copied from IBC Table 1604.3).

**TABLE 4—CLEARANCE TO COMBUSTIBLES**

Unit front, sides, rear:	2"
Combustible Floor:	6"
Combustible Sheathing above opening top:	8"
Sheathing or trim to opening sides:	8"
Mantle above opening	12"
Opening to sidewall:	24"
Hearth extension beyond front:	20"
Hearth extension beyond sides:	12"
Insulation from firebox:	2"

**Fireplace Parts Diagram for Combustible Floors**

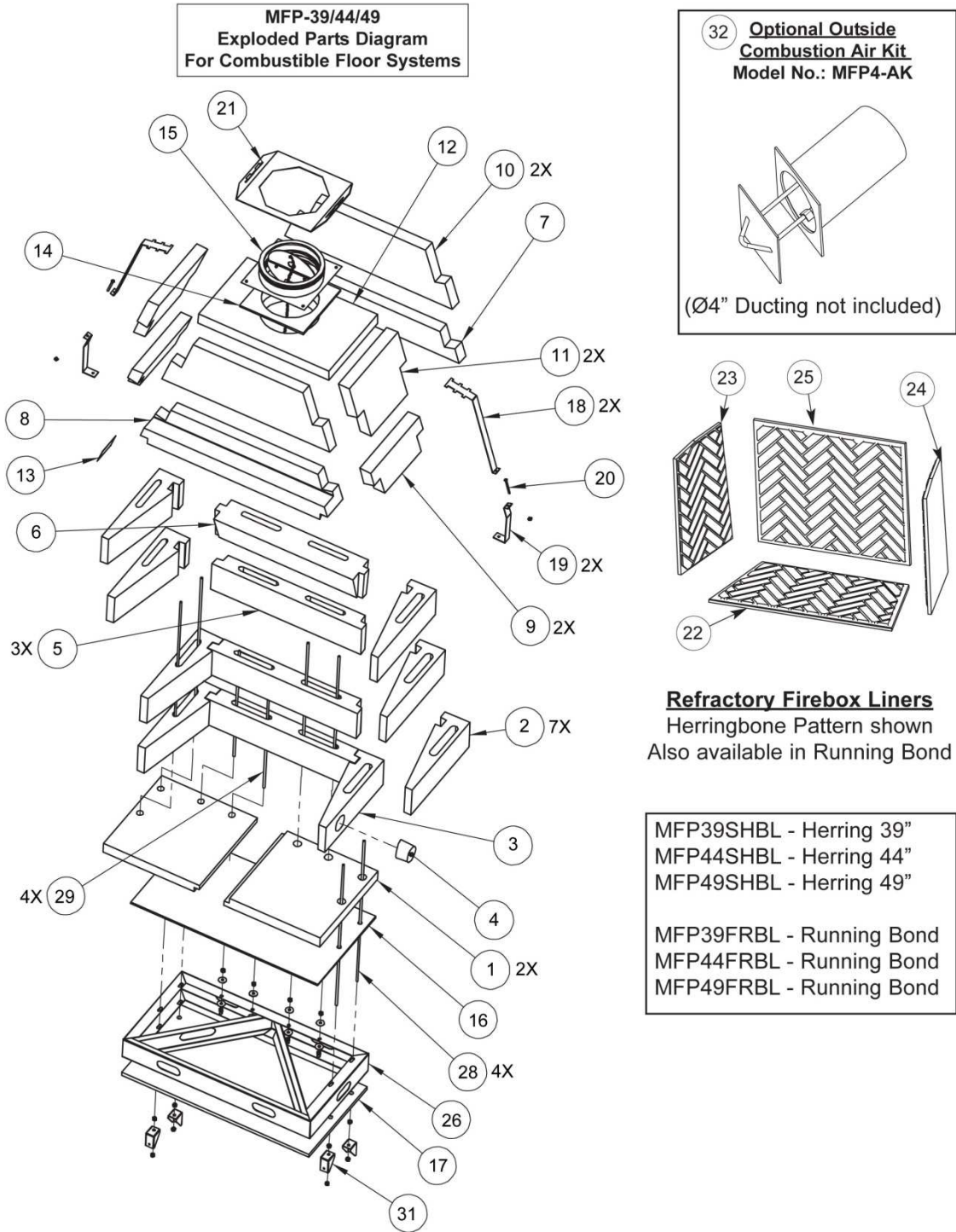

Note: See MFI installation instructions for a complete description of the numbered items.

**FIGURE 1**

**Fireplace Parts Diagram for Non-Combustible Floors**

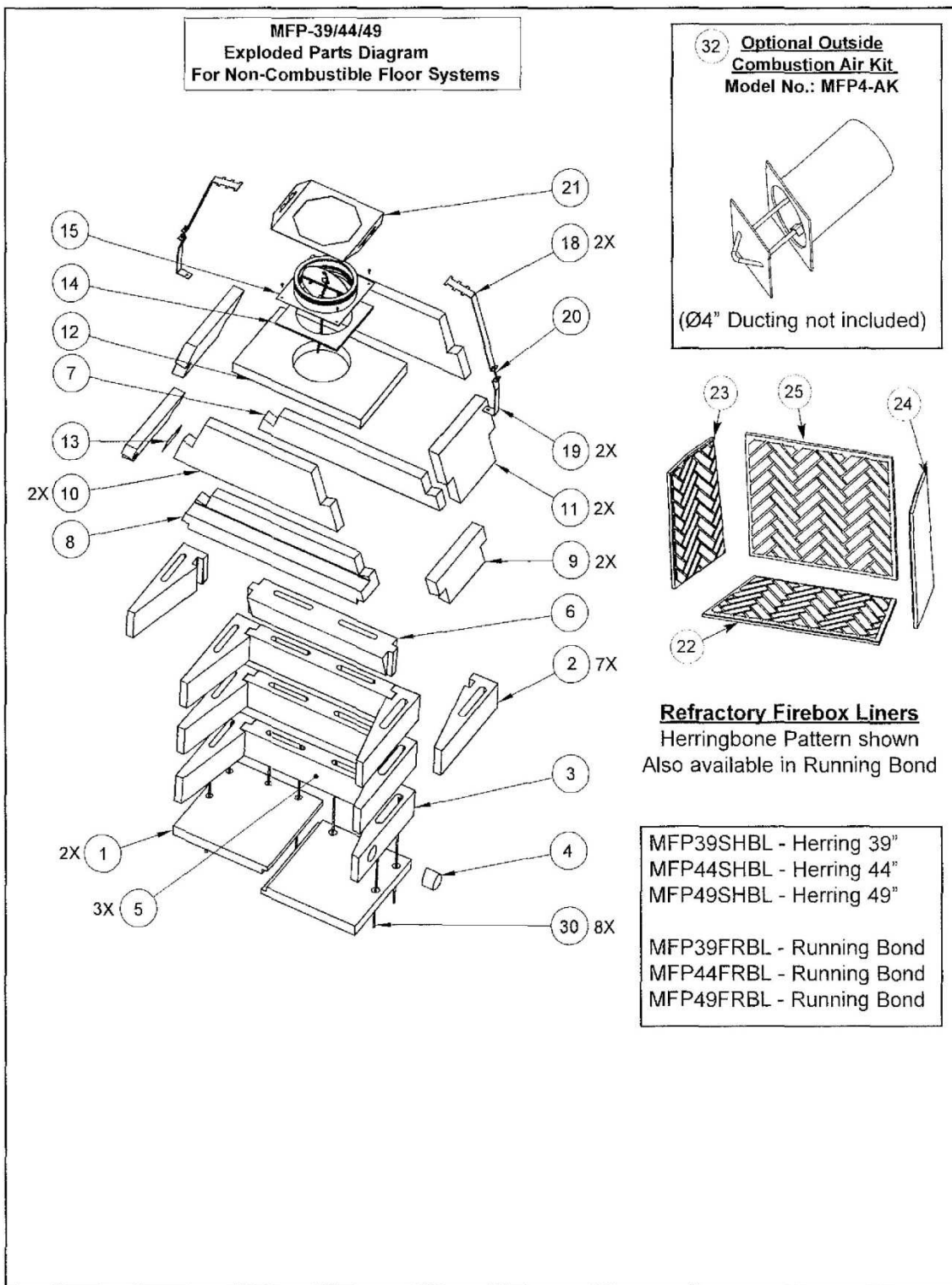

Note: See MFI installation instructions for a complete description of the numbered items.

**FIGURE 2**

Attach seismic straps (seismic designed categories D, E & F) to rebar prior to placing final side walls.

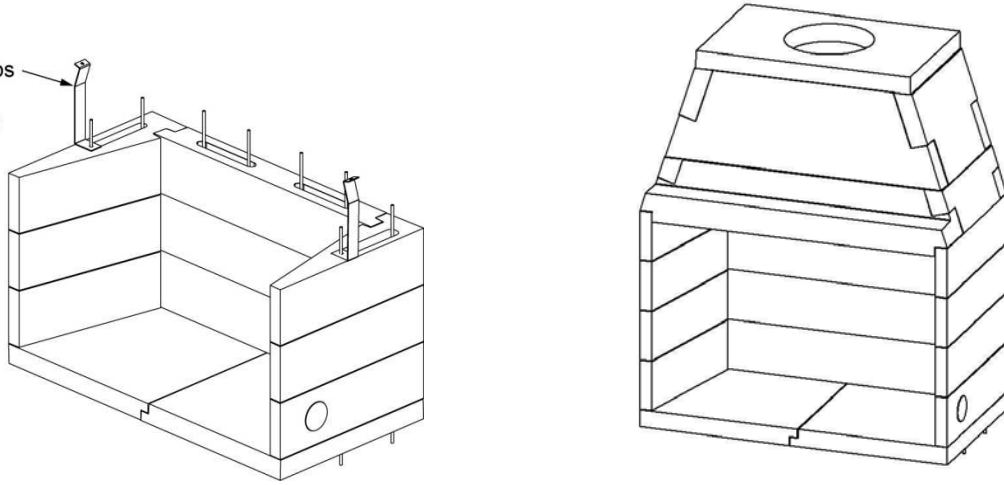

FIGURE 3—MASON-LITE ASSEMBLED FIREBOX COMPONENTS

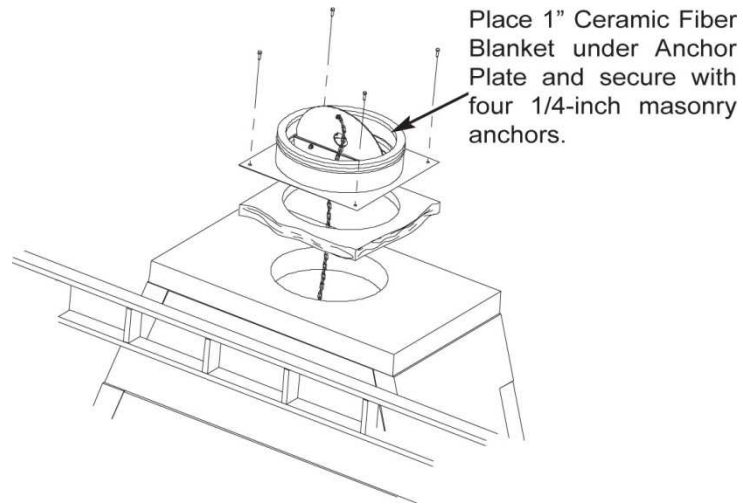

FIGURE 4

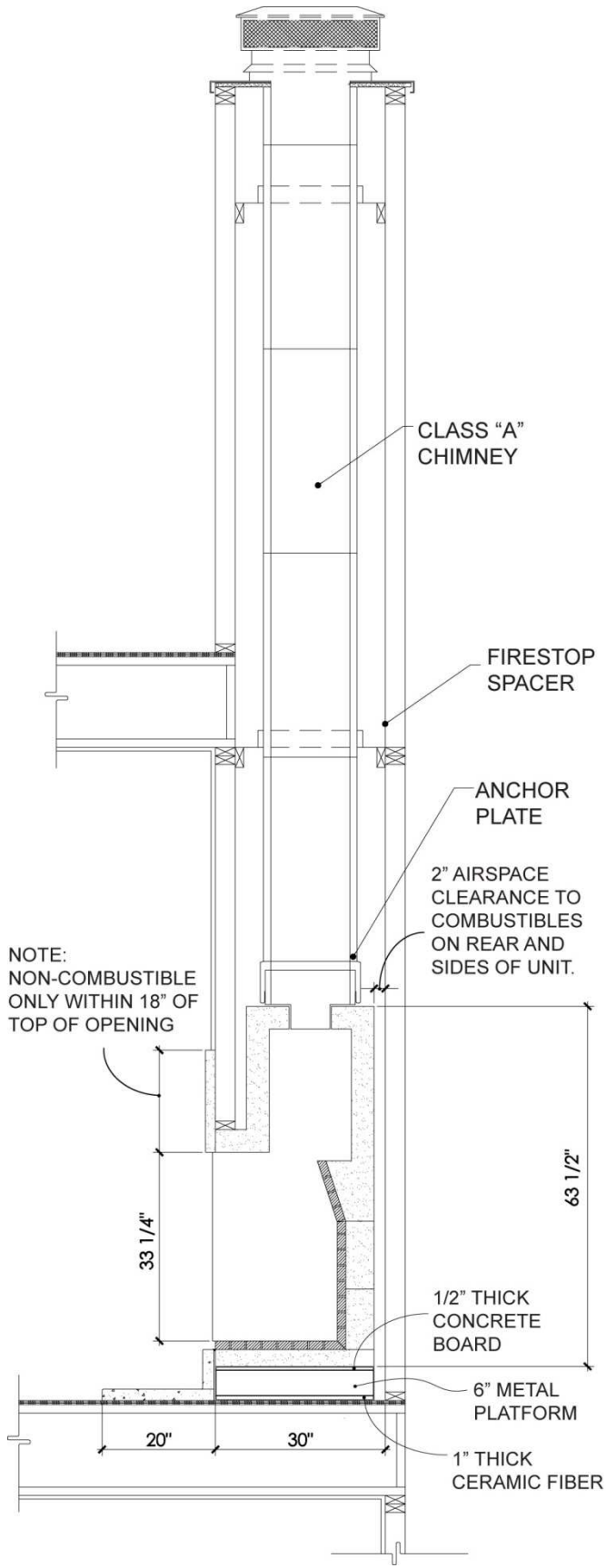

FIGURE 5

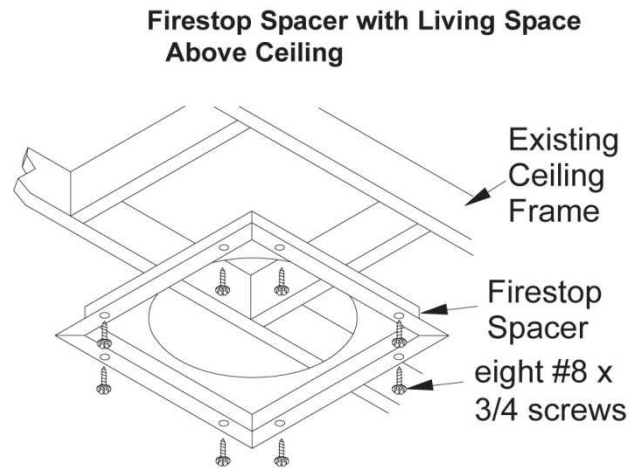

FIGURE 6

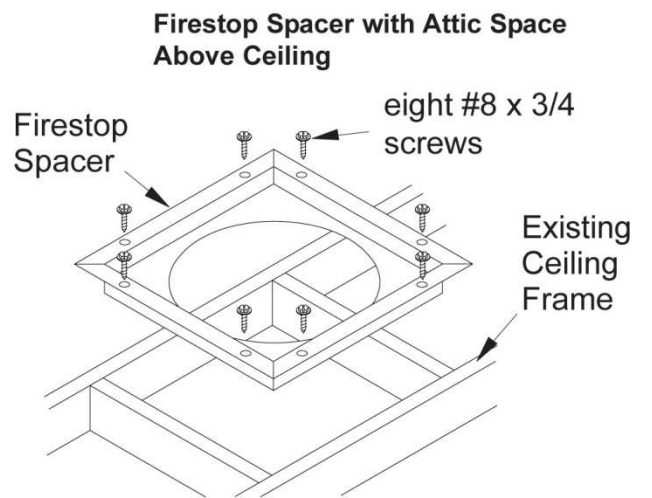
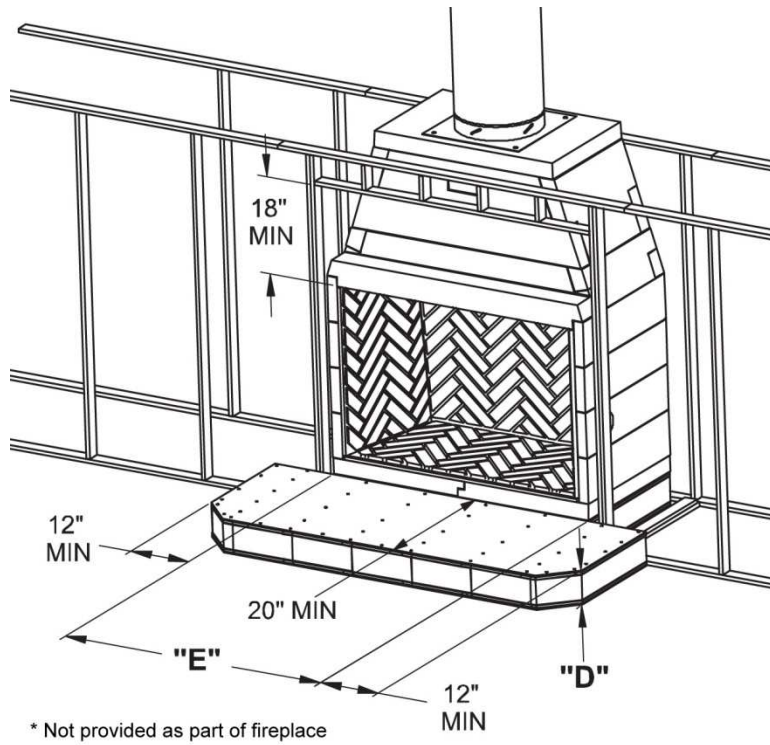

FIGURE 7



MODEL	D	E
MFP-39	7-1/4"	43"
MFP-44	7-1/4"	48"
MFP-49	7-1/4"	53"

FIGURE 8